



Flameproof motors with brake
Moteurs antidéflagrants avec frein
Explosionsgeschützte Motoren mit Bremse
Motores antideflagrantes con freno
Motori antideflagranti con freno

63 ÷ 225

II 2G, II 2GD

EEx-d, EEx-de • IIB, IIC

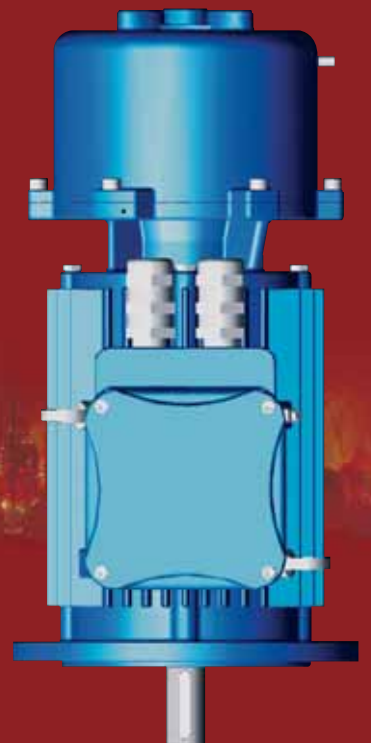

cemp

Flameproof
Motors



Atav - Les Ateliers de l'Avre

is a Cemp SpA trademark

cemp

Flameproof
Motors



Flameproof motors with brake
Moteurs antidéflagrants avec frein
Explosionssgeschützte Motoren mit Bremse
Motores antideflagrantes con freno
Motori antideflagranti con freno

63 ÷ 225

II 2G, II 2GD

EEx-d, EEx-de • IIB, IIC

GB CONTENTS

	Page
1. General information	7
1.1 Range of ATEX flameproof motors with brake	7
1.2 Main characteristics	8
1.3 Main options	8
1.4 Nomenclature	9
2. Design features	10
2.1 Materials, painting and nameplate	10
2.2 Bearing system	11
2.3 Terminal box	12
2.4 Construction details of brake	14
3. Electrical design	16
3.1 Connecting diagrams	16
3.2 Permissible starts per hour	17
4. Performance data	67
4.1 Three-phase motors, 1 speed	68
4.2 Three-phase motors, 2 speeds, for general purpose	76
4.3 Three-phase motors, 1 speed, for hoist applications	80
4.4 Three-phase motors, 2 speeds, for hoist applications	82
5. Overall dimensions	89
5.1 Motors with integrated brake	90
5.2 Motors with external brake	94
6. Spare parts	97
6.1 Motors with integrated brake	98
6.2 Motors with external brake	102

F SOMMAIRE

	Page
1. Informations générales	19
1.1 Gamme des moteurs antidéflagrants ATEX avec frein	19
1.2 Caractéristiques principales	20
1.3 Options principales	20
1.4 Identification de la référence commerciale	21
2. Caractéristiques mécaniques	22
2.1 Matériaux, peinture et plaque signalétique	22
2.2 Roulements	23
2.3 Boîte à bornes	24
2.4 Particularités de fabrication du frein	26
3. Caractéristiques électriques	28
3.1 Schémas de branchement	28
3.2 Nombre de démarrages tolérés par heure	29
4. Données nominales	67
4.1 Moteurs triphasés, 1 vitesse	68
4.2 Moteurs triphasés, 2 vitesses, pour usage général	76
4.3 Moteurs triphasés, 1 vitesse, pour levage	80
4.4 Moteurs triphasés, 2 vitesses, pour levage	82
5. Dimensions	89
5.1 Moteurs à frein intégré	90
5.2 Moteurs à frein externe	94
6. Pièces détachées	97
6.1 Moteurs à frein intégré	98
6.2 Moteurs à frein externe	102

D INHALTSVERZEICHNIS

	Seite
1. Allgemeine Informationen	31
1.1 Produktpalette der explosionsgeschützten ATEX - Motoren mit Bremse	31
1.2 Hauptmerkmale	32
1.3 Hauptausführungen	32
1.4 Bedeutung der Kürzel	33
2. Mechanische Eigenschaften	34
2.1 Material, Lackierung und Typenschild	34
2.2 Lager	35
2.3 Klemmenkasten	36
2.4 Konstruktionsmerkmale der Bremse	38
3. Elektrische Eigenschaften	40
3.1 Schaltung	40
3.2 Zulässige Anläufe pro Stunde	41
4. Betriebsdaten	67
4.1 Drehstrom Motoren, 1 Drehzahl,	68
4.2 Drehstrom Motoren, 2 Drehzahlen, für den allgemeinen Gebrauch	76
4.3 Drehstrom Motoren, 1 Drehzahl, Hubmotoren	80
4.4 Drehstrom Motoren, 2 Drehzahlen, Hubmotoren	82
5. Abmessungen	89
5.1 Motoren mit integrierter Bremse	90
5.2 Motoren mit äußerer Bremse	94
6. Ersatzteilliste	97
6.1 Motoren mit integrierter Bremse	98
6.2 Motoren mit äußerer Bremse	102

1. General information

1.1 Range of ATEX flameproof motors with brake

1.1 Range of ATEX flameproof motors with brake

The motors offered in this catalogue comply with standards concerning equipment and protective systems intended for use in potentially explosive atmospheres, in compliance with European Directive 94/9/EC dated 23/3/94, otherwise known as the ATEX directive.

The ATEX directive states that two different certificates of conformity are to be issued.

One is the "EC-Type examination certificate" for the homologation of the prototype and the other is for the "Production Quality Assurance Notification".

The Certificates are issued by CESI in Milan, Notified Body no. 0722.

All motors in the ATEX series are available in 2G (for gas) or 2GD (for gas and dust) versions.

GB

Table 1 A - Range of ATEX flameproof motors with brake

Version	Frame size [mm]	Output range [kW]	Brake	Ventilation	Operation	Temp. class (2G)	Maximum surface temperature (2GD)	Motor type			
								EEx-d IIB	EEx-de IIB	EEx-d IIC	EEx-de IIC
Single speed, three phase (2, 4, 6, 8 pole)	63 ÷ 160	0.18 ÷ 18.50	Integrated	Unventilated IC410	S2, S4 40%	T4	T 135°C	DB 30	DB 35	DC 30	DC 35
	71 ÷ 160	0.37 ÷ 18.50	Integrated	Self-vent. IC411	S1, S9	T4	T 135°C	HB 30	HB 35	HC 30	HC 35
Single speed, three phase (4, 6, 8 pole)	180 ÷ 225	22.00 ÷ 43.00	External	Unventilated IC410	S2, S4 40%	T4	T 135°C	PB 30	PB 35	PC 30	PC 35
Two speeds, three phase (2/4, 4/8, pole) for general purpose	63 ÷ 160	0.15 ÷ 15.00	Integrated	Unventilated IC410	S2, S4 40%	T4	T 135°C	DB 20	DB 25	DC 20	DC 25
	71 ÷ 160	0.20 ÷ 15.00	Integrated	Self-vent. IC411	S1, S9	T4	T 135°C	HB 20	HB 25	HC 20	HC 25
	180 ÷ 225	15.00 ÷ 40.00	External	Unvent. IC410	S2, S4 40%	T4	T 135°C	PB 20	PB 25	PC 20	PC 25
Motors for lifting*											
Single speed, three phase (6 pole)	71 ÷ 160	0.18 ÷ 11.00	Integrated	Unventilated IC410	S2, S4 40%	T4	T 135°C	DB 50	DB 55	DC 50	DC 55
	71 ÷ 160	0.18 ÷ 11.00	Integrated	Self-vent. IC411	S2, S4 40%	T4	T 135°C	HB 50	HB 55	HC 50	HC 55
	180 ÷ 225	15.00 ÷ 30.00	External	Unventilated IC410	S2, S4 40%	T4	T 135°C	PB 50	PB 55	PC 50	PC 55
Two speeds, three phase (2/8, 4/12, 4/16, pole)	71 ÷ 160	0.06 ÷ 7.50	Integrated	Unventilated IC410	S2, S4 40%	T4	T 135°C	DB 50	DB 55	DC 50	DC 55
	71 ÷ 160	0.06 ÷ 7.50	Integrated	Self-vent. IC411	S2, S4 40%	T4	T 135°C	HB 50	HB 55	HC 50	HC 55
	180 ÷ 225	2.00 ÷ 20.00	External	Unventilated IC410	S2, S4 40%	T4	T 135°C	PB 50	PB 55	PC 50	PC 55

* Polarities shown in this section are specifically referred to motors for use with high starting torques. For alternative polarities please refer to general purpose motors.

For motors in DB and DC series frame size 90 and above are available with optional force ventilation, IC416. For motors in PB and PC series all frames available with optional force ventilation, IC416.

Table 1 B - Temperature Class upon request

Version	T3	T5 (unventilated not included)
63 ÷ 132	Same power as T4	Same power as T4 (*)
160 ÷ 225	Same power as T4	Power lower than T4

(*) For 2-speed motors: power lower than T4.

1.2 Main characteristics

1.3 Main options

GB

1.2 Main characteristics

- Explosion-proof motors according to European standard CENELEC EN 50 014, EN 50 018 and EN 50 019 (for terminal box EEx-de)
European standards are acknowledged and adopted by the member countries of CENELEC (European Committee for Electrotechnical Standardization) and accepted by almost all countries worldwide.
- 2G motors for classified areas zone 1 and zone 2 (GAS).
- Squirrel cage three-phase asynchronous motors.
- Totally enclosed, IP55 frame with IP65 terminal box.
- Dimensions to IEC 60072 standards.
- Mounting options B3, B5, B35, B14, B34.
- Power Supply 400V / 50Hz.
- Class F insulation.
- Noise level within 80 dB (A).
- Terminal Box:
 - available both in a flameproof, or increased safety version
 - large size
 - standard position - top, opposite feet
 - rotate by 90° in 4 positions.
- Motor frame and terminal box enclosure separated to avoid the transmission of explosions.
- Winding cables connected to the terminal board by means of terminal blocks or by a flameproof sealing device.
- High protection against corrosion:
 - inside and outside surfaces poly-ester powder painting (minimum thickness 150 µm)
 - stainless steel nameplate
 - anticorrosion plated fasteners.
- Highly resistant to impact:
 - frame, terminal box and cast iron endshields.
 - fan cover in sheet steel.
- Low friction dust seals.
- The conformity certificates also cover alternatives, such as:
 - altitude over 1000m
 - modification of the rated voltage and rated frequency
 - power supply from an inverter
 - motor protection through temperature detectors
 - duty S1 to S9.

Note:

Further information is available in the flameproof motors catalogue 14.

1.3 Main options

Main versions

- 2GD motors for areas classified as zone 21 and zone 22 (Dust).

Electrical variants

- Non-standard voltages and frequencies (maximum voltage 690V).
- Motors for tropical climates.
- Motors for low ambient temperatures.
- Temperature rise below 80K.
- Motors insulated to class H.
- Motors with bimetallic detector, thermistor PTC or thermistor PT100.
- Motors with anti-condensation heaters.
- Motors with special electrical design.

Mechanical variants

- Special flanges and shafts.
- Double ended shafts.
- Cable gland fitted to terminal box.
- Terminal box with special cable entries.
- Motors protection IP56 - IP65 - IP66.
- Motors with condensation drainage valves.
- Motors with special bearings (with sensors, insulated, oversized).
- Motors with rain cap or sun shield.
- Separate terminal box for auxiliary terminals.

Accessories

- Motors suitable for frequency inverter drive.
- Motors with encoder.
- Motors with forced ventilation (from frame size 90).

Brake variants

- D.C. current brake
- Positive brake (brakes when energized) with uninterrupted current.

Certificates

- Motors according to R.I.Na., American Bureau of Shipping, Bureau Veritas, Det Norske Veritas, Germanischer Lloyd, Korean Register of Shipping, Lloyd Register of Shipping, ... design

1.4 Nomenclature

1.4 Nomenclature

GB

Pos. 1 = Motor series:

D	Unventilated flameproof motors with brake 63÷160	H	Self-ventilated flameproof motors with brake 71÷160
P	Unventilated flameproof motors with brake 180÷225		

Pos. 2 = Type of application:

B	Enclosure group IIB	
C	Enclosure group IIC	

Pos. 3 = Type of motor (electric characteristics):

2	Three-phase 2 speed, constant torque	5	For hoist applications
3	Three-phase 1 speed	7	For inverters

Pos. 4 = Terminal box version:

0	Protection method EEx-d	5	Protection method EEx-e
3	Without box, with plate EEx-d	2	EEx-d oversized box

Pos. 5 = Size (centre height):

63	90	132	200
71	100	160	225
80	112	180	

Pos. 6 = Length of stator pack:

	63	71	80	90	100	112	132	160	180	200	225			
							*	*						
Extra short							SA							
Short	A	A	A	S	LA		SB	S	MA		LA	S		
Medium						M	MB	M	MB	M	M			
Long	B	B	B	L	LB		ML	L	L	L	LB	M		
Extra long			L									ML		

* Three-phase, 2-speed version

Pos. 7 = Polarity:

2	2 poles	24	Double polarity: 2 / 4 poles	48	Double polarity: 4 / 8 poles
4	4 poles	28	Double polarity: 2 / 8 poles	41	Double polarity: 4 / 12 poles
6	6 poles			43	Double polarity: 4 / 16 poles
8	8 poles				

Pos. 8 = Mounting (IM Code I)

B3			
B5			
B14			
B34			
B35			

Pos. 9 = Supply:

3F xxxD / xxxS / xx	Three-phase 1-speed; voltage for delta connection; voltage for star connection; frequency
3F xxx / xx	Three-phase, 2-speed: voltage; frequency

D B 3 0 90 L 4 B5 3F 230D/400S/50 = Example of the commercial codes

2. Design features

2.1 Materials, painting and nameplate

2.1 Materials, painting and nameplate

Materials

Table 2 A - Materials of main components:



	Series DB - DC 63 ÷ 160	Series HB - HC 71 ÷ 160	Series PB - PC 180 ÷ 225
Frame Endshields Terminal box	Cast iron G200 (ISO 185)	Cast iron G200 (ISO 185)	Cast iron G200 (ISO 185)
Fan cover Rain cap	---	Steel	---
Fan	---	Non sparking thermoplastic material or aluminium	---
Shaft	Steel C40	Steel C40	Steel C40
Rotor	Squirrel cage in pressure cast aluminium	Squirrel cage in pressure cast aluminium	Squirrel cage in pressure cast aluminium
Winding	Insulation class F or H	Insulation class F or H	Insulation class F or H
Bolts and screws	Steel 8.8 zincd	Steel 8.8 zincd	Steel 8.8 zincd
Cable gland (on request)	Brass or stainless steel	Brass or stainless steel	Brass or nickel-plated brass
Brake enclosure	Cast iron	Cast iron	Cast iron - Aluminium
Brake terminal box	---	---	Aluminium

Painting - Table 2 B - Paint system and characteristics

Pre-treatment	All components are cleaned and degreased; cast iron and aluminium parts are sanded down
Painting	Dust paint on poly-ester resin base, polymerized in oven at 200 °C
Thickness	Total 150 µm
Colour	RAL 5010
Mechanical strength	Non-abrasive, elastic, insensitive to scratches, resistant to impact
Corrosion resistance	Highly resistant to water, water vapour, salt water
Chemical resistance	Good resistance in chemically aggressive environments
Operating temperature	-40 °C +130 °C

The standard paint system with colour RAL 5010, is an acid-protection for heavy duty applications. Upon request, special colours are available by application of a final coat to the standard paint.

Nameplate

  	
0722 CESI 03ATEX111 n000001 y04	
Electric Motor DB30 90L 4 3~	
II 2GD EExd IIB T4 IP65	
⊕	⊖
V	A
230Δ	6,24
400λ	3,60
Hz	1/min
50	1470
cos φ	kW
0,79	1,50
Brake MEC80 AC 400V/3~	140 VA
IC410 CLF Ta40 °C S2	35 Nm
J 0.283 kgm ²	kg 43
Manufacturer Cemp SpA - I 20030 SENAGO (Milan) - ITALY	
regrease joints after any dismantling - fasteners quality 8.8 EN 20898	

The stainless steel nameplate is fitted on the motor frame.

The brake on the PB - PC series motors is fitted with its own nameplate.

Fig. 2 A

2.2 Bearing system

2.2.1 Bearing system

2.2.2 Bearing section

2.2.1 Bearing system

Standard motors are fitted with double-shield radial ball bearings (pre-lubricated ZZ series) or other special bearings on customer request.

Lubrication

The ZZ series bearings are lubricated for life and require no further lubrication.

Bearing Seal

In order to prevent dust and water penetration, a seal ring is fitted to the endshield on the driving and non-driving ends.

These seal rings are highly resistant to vibrations, thermally stable, and resistant to mineral oils and diluted acids.

Seals for media not listed above are available on request.

GB

Table 2 C - Types of bearings

Motor	Bearings	
Frame size	Drive end	Non-Drive end
63	6202 ZZ	6202 ZZ
71	6203 ZZ	6203 ZZ
80	6204 ZZ	6204 ZZ
90	6205 ZZ	6205 ZZ
100	6206 ZZ	6206 ZZ
112	6306 ZZ	6306 ZZ
132	6308 ZZ C3	6308 ZZ C3
160	6309 ZZ C3	6309 ZZ C3
180	6310 ZZ C3	6310 ZZ C3
200	6312 ZZ C3	6312 ZZ C3
225	6313 ZZ C3	6313 ZZ C3

2.2.2 Bearing section

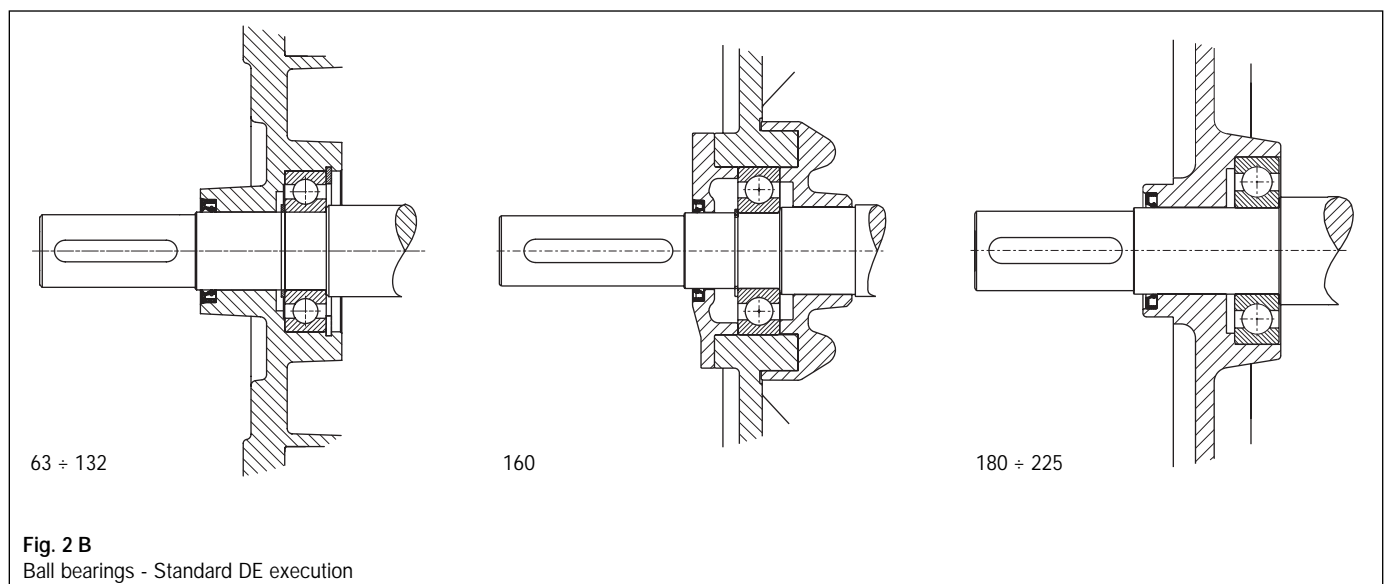

2.3 Terminal box

2.3.1 Terminal box design

2.3.1 Terminal box design

The standard design has four basic versions:

- EEx-d IIB
- EEx-d IIC
- EEx-de IIB
- EEx-de IIC

Other alternatives available depending on customer requirements, i.e. additional terminal box for auxiliary terminals.

GB

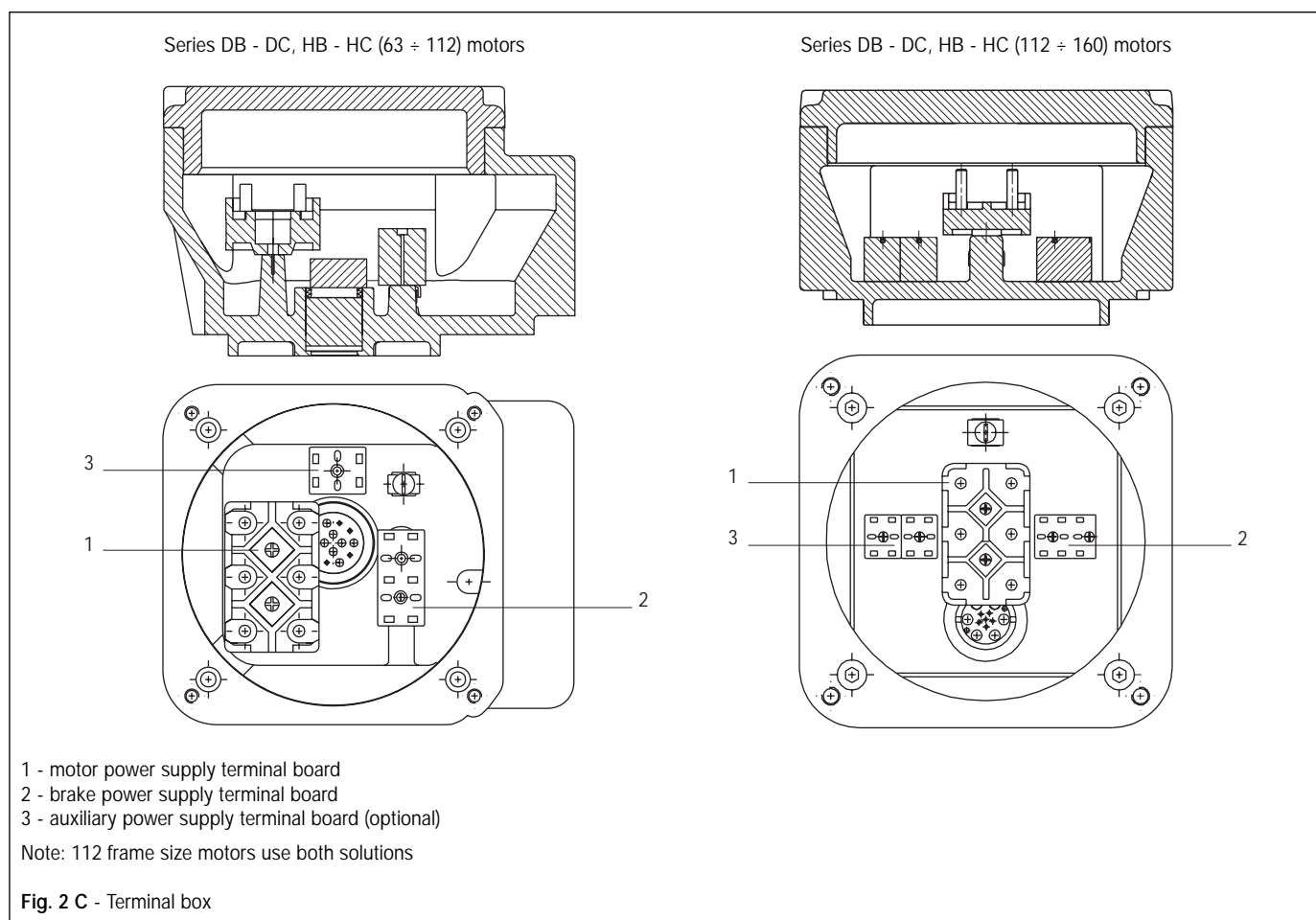

2.3

2.3.1 Terminal box design

2.3.2 Position of terminal box and cable entries

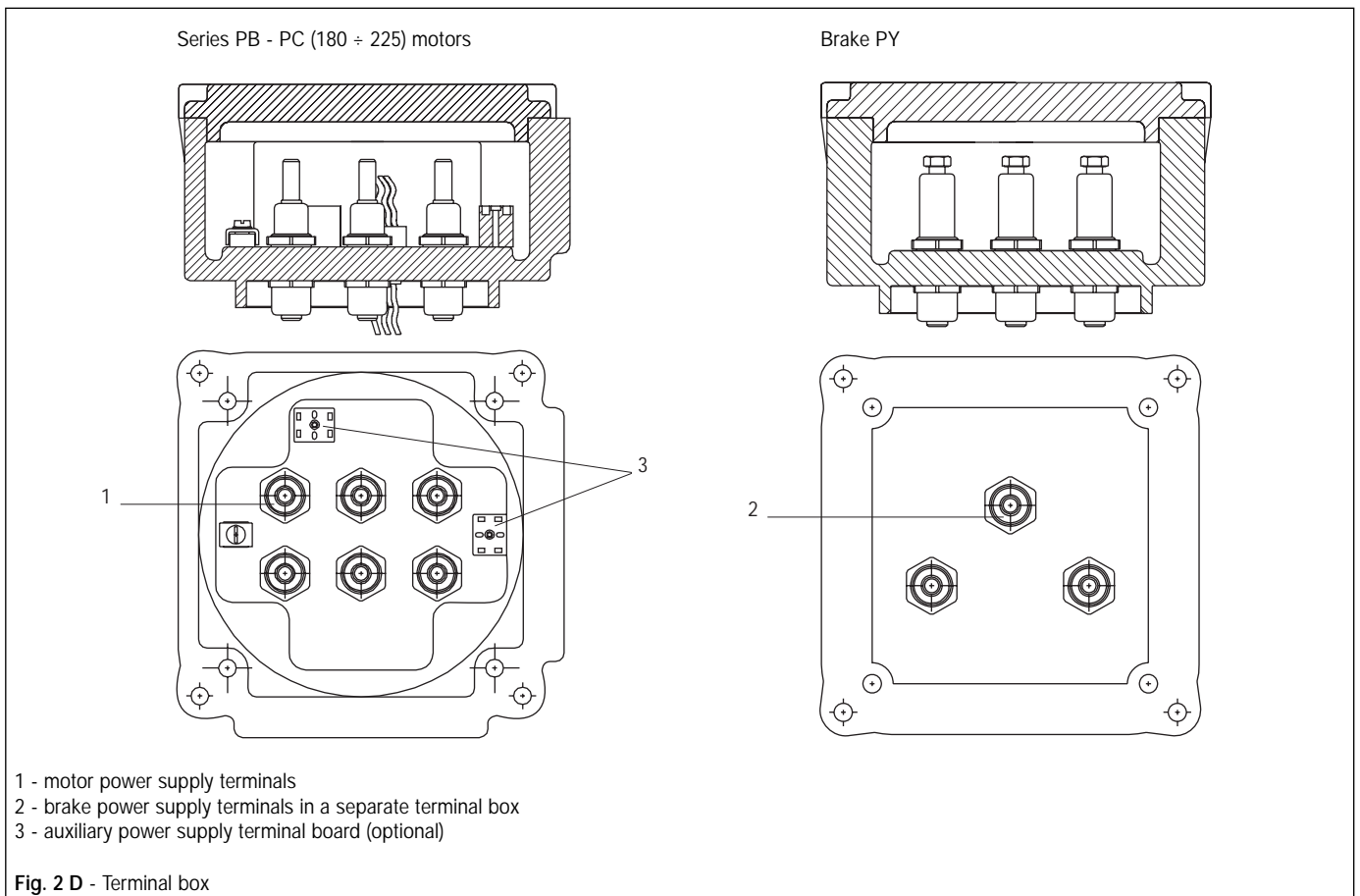

GB

2.3.2 Position of terminal box and cable entries

The terminal box is usually located on top and can be turned through $4 \times 90^\circ$ (Fig. 2 E).

For a horizontal mounted motor the cable entry is normally located on the right side (looking at the driving-end).

Cable entry:

- standard position: 1
- special positions upon request: 2, 3, 4.

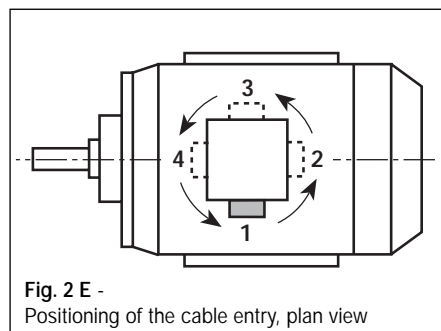

2.4 Construction details of brake

2.4.1 Series DB - DC (63 ÷ 160) and HB - HC (71 ÷ 160)

2.4.1 Series DB - DC (63 ÷ 160) and HB - HC (71 ÷ 160)

Construction method

Motors in these two series are built with an integrated brake and are considered as an integral unit, consequently, a single ATEX certificate is provided for both motor and brake.

The brake is enclosed in a special enclosure built with a EEx-d IIB or IIC protection type and IP65 mechanical protection.

The temperature class and maximum surface temperature are those of the motor.

The electro-magnet winding is encapsulated in resin which isolates it and provides mechanical protection.

Electro-magnet supply-three-phase, voltage from 48V to 690V.

The electrical connection is made inside the terminal box.

Operation

The brake is made up of:

- the magnet;
- the counter-magnet (or mobil armature) supported by three small columns where it can slide;
- braking disk
- toothed hub secured to the motor shaft.

When the coil is powered, the magnet attracts the mobil armature which thus releases the braking disk so the motor can rotate freely.

By removing voltage to the magnet, the springs push the mobil armature against the braking disk, which, by creating friction against the motor shield, locks the shaft rotation.

In rest conditions, when the brake is not powered, the motor remains locked.

Braking torque calibration

The motor is supplied with a ready-to-use calibrated brake.

Special calibration available on request. This is carried out during assembly before final testing.

On request, higher braking torques available than those listed in 2 D.

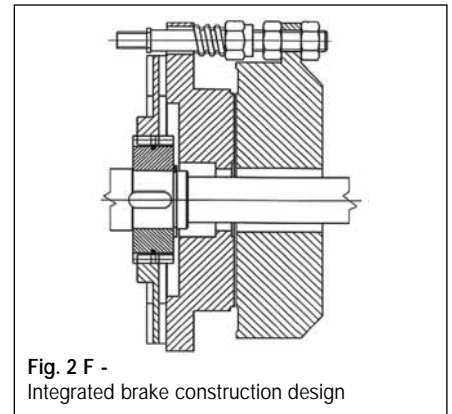

Fig. 2 F -
Integrated brake construction design

Table 2 D - Standard technical data of the integrated brake

Frame size	Brake model	Static braking torque [Nm]	Air gap (+0.1 / 0) [mm]	On-off braking time requested [ms]	Number of disks [n°]	Maximum speed [min]	Power [VA]
63	AC1	4	0.2	20	1	3600	40
71	MEC 63	9	0.3	25	1	3600	50
80	T80	17	0.3	30	1	3600	60
90	MEC 80	35	0.3	40	1	3600	140
100	MEC 90 (◆)	48	0.3	40	1	3600	180
112	MEC 100 (◆)	70	0.3	45	1	3600	250
132	MEC 110 (◆)	90	0.3	90	2 (▼)	3600	400
160	T140	130	0.3	100	1	3600	480

(◆) 2 braking disks available on request

(▼) With a single disk, the torque is halved

Manual release (71 ÷ 160)

DB - DC e HB - HC series flameproof motors with brake can be supplied on request with hand release lever for the brake.

Pressure is applied on the release mechanism which moves the mobile armature, freeing the motor's shaft.

When releasing pressure on the mechanism the brake automatically returns to the fail safe position.

Variants

On request: brake motors can be supplied with single-phase power supply brakes between 110V and 400V. This version is only available in the EEx-d version, the terminal box contains a rectifier.

- supplied with D.C. current between 24V and 260V

- positive braking-when power is applied the brake activates and locks on. With the power supply off the brake is not energized and the motor shaft rotates freely. The positive brake is available only with D.C. current for motors with 71 ÷ 100 axis height.

2.4

2.4.1

2.4.2 Series PB - PC (180 ÷ 225)

2.4.2 Series PB - PC (180 ÷ 225)

Construction method

This series is made by combining an ATEX flameproof motor with an external brake, which comes with its own ATEX certificate consistent with the one of the motor.

The active part of the brake is housed in its own flameproof enclosure built with EEx-d IIB or IIC protection type and IP65 mechanical protection.

The brake choice is made so that the enclosure group and the temperature class or maximum surface temperature are compatible with those of the motor.

The brake is provided with its own terminal box and must be powered with its own line.

The power supply must only be three-phase single voltage.

Series PB - PC motors with brake can operate horizontally.

Vertical application can be considered on request.

Operation

The brake is made up of:

- the magnet;
- the counter-magnet (or mobile armature);
- braking disks;
- toothed hub;
- friction disks;
- adjustment ring nut.

When the coil is on, the magnet attracts the mobile armature which thus releases the braking disk so the motor can rotate freely.

By removing the voltage to the magnet, the springs push the mobile armature against the braking disk.

In rest conditions, when the brake is not powered, the motor remains locked.

Braking torque setting

The motor is supplied ready-to-use with a calibrated brake.

Special calibration available on request. This is carried out during assembly before final testing.

Features are listed in the 2 E chart.

Manual release

Not available with this series of motors.

Certifications

The conformity certificate to the ATEX (94/9/CE) Directive on brakes combined with PB - PC motors is issued by the INERIS (Notified Body No. 0080) with the following number: 03 ATEX 0022.



Figura 2 G - External brake construction design

GB

Table 2 E - Standard technical data of the external brake

Brake model	Static braking torque [Nm]	Air gap (+0.1 / 0) [mm]	On-off braking time requested [ms]	Number of disks [n°]	Maximum speed [min]	Power [VA]
PY2 A*	50	0.2	60	1	3000	395
PY2 B*	80	0.3	60	2	3000	395
PY2 C*	120	0.3	60	3	3000	395
PY3 A*	160	0.3	80	1	3000	670
PY3 B	250	0.3	80	2	3000	670
PY3 C	320	0.3	80	3	3000	670

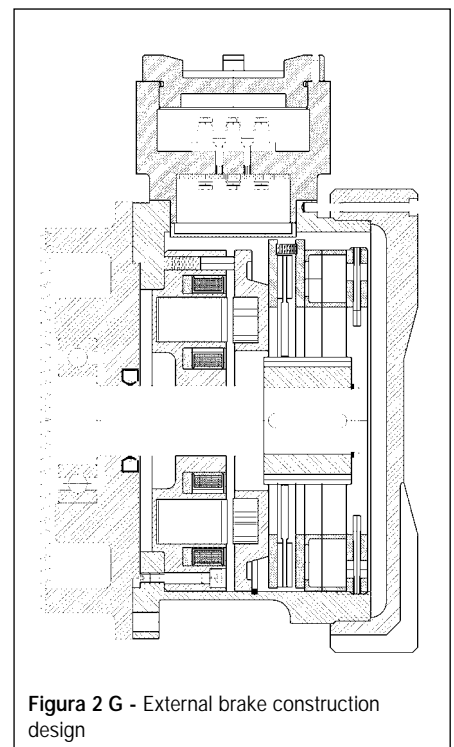
* available on request

3. Electrical design

3.1 Connection diagrams

3.1 Connection diagrams

GB

Connection to motor

Three-phase motors, single speed

Δ - Delta connection

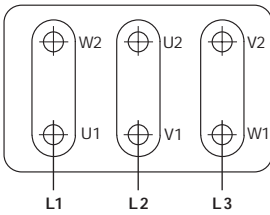

Y - Star connection

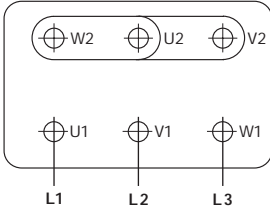

Three-phase motors, two speed, one winding

▬ - High speed connection

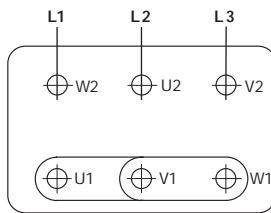

▬ - Low speed connection

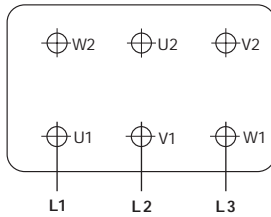

Three-phase motors, two speed, two windings

▬ - High speed connection

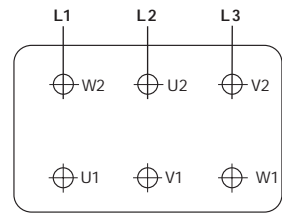

▬ - Low speed connection

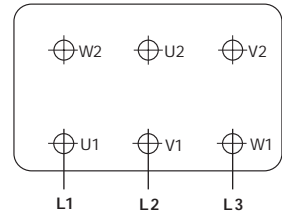

Brake connection with separate power supply

Three-phase A.C. brake

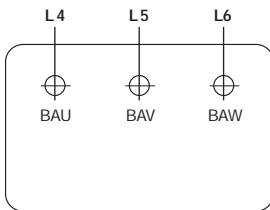

Motor power supply line
= L1, L2, L3

Brake power supply line
= L4, L5, L6

The rotation direction is reversible by inverting the two phases.

Fig. 3 A - Motor and brake connection diagrams

Other connection diagrams between motor and brake are available, including a single power supply for motor and brake, or power supply on the same terminal board.

Connection diagrams that provide single-phase or D.C. power supply are also available.

3.2 Permissible starts per hour

3.2 Permissible starts per hour

The number of permitted starts per hour of intermittent running motors is determined by the duty type and characteristics of the load, and particularly by the moment of inertia.

The moment of inertia actually determines the time required to start and stop the motor along with the temperature that the motor and brake will reach during operation.

The nameplate always provides information on the duty type, number of starts and moment of inertia of the load.

Chart 3 A lists the number of permissible start per hour with reference to motors in S4 service with an operating time equal to 40%.

A feasibility study is generally required for duty types or moment of inertia different from those listed in the table.

GB

Table 3 A

Rated power [kW]	Permissible starts per hour with PTC [1/h]															
	2 pole				4 pole				6 pole				8 pole			
	FI=1.5	FI=2	FI=3	FI=4	FI=1.5	FI=2	FI=3	FI=4	FI=1.5	FI=2	FI=3	FI=4	FI=1.5	FI=2	FI=3	FI=4
0.05	---	---	---	---	---	---	---	---	---	---	---	---	830	670	550	440
0.09	---	---	---	---	---	---	---	---	420	360	290	240	---	---	---	---
0.12	---	---	---	---	310	270	220	180	---	---	---	---	---	---	---	---
0.15	---	---	---	---	---	---	---	---	---	---	---	---	830	670	550	440
0.18	270	230	190	150	310	270	220	180	420	360	290	240	830	670	550	440
0.25	240	210	170	150	270	240	200	160	380	320	260	210	740	600	490	390
0.37	240	210	170	130	270	240	200	160	380	320	260	210	740	600	490	390
0.55	230	190	160	130	260	230	180	150	350	300	240	200	690	560	460	370
0.75	280	240	190	120	320	280	220	150	440	370	290	200	860	690	560	370
1.10	170	150	120	120	200	170	150	120	270	230	190	160	530	430	360	300
1.50	170	150	120	100	200	180	150	120	270	240	190	160	530	440	360	300
2.20	160	140	120	100	180	160	140	120	240	210	180	160	470	400	350	300
3.00	120	110	90	100	130	120	110	90	180	160	140	120	340	300	260	220
4.00	120	110	90	80	130	120	110	90	180	160	140	120	340	300	260	220
5.50	90	80	60	80	100	90	70	60	130	120	100	80	260	220	180	150
7.50	90	80	60	50	100	90	70	60	130	120	100	80	260	210	180	150
8.80	---	---	---	---	100	90	70	60	---	---	---	---	---	---	---	---
9.20	90	80	60	50	---	---	---	---	---	---	---	---	---	---	---	---
11.00	90	80	60	50	100	90	70	60	130	120	100	80	260	210	180	150
15.00	90	80	60	50	100	90	70	60	130	120	100	80	260	210	180	150
18.50	70	60	50	40	80	70	60	50	110	100	80	70	220	180	150	121
22.00	70	60	50	40	80	70	60	50	110	100	80	70	220	180	150	130
30.00	70	60	50	40	80	70	60	50	110	100	80	70	---	---	---	---
37.00	60	50	50	40	70	60	50	40	---	---	---	---	---	---	---	---
45.00	60	50	40	40	70	60	50	40	---	---	---	---	---	---	---	---

4. Performance data

- 4.1 Three-phase motors, 1 speed
- 4.2 Three-phase motors, 2 speeds, for general purpose
- 4.3 Three-phase motors, 1 speed, for hoist applications
- 4.4 Three-phase motors, 2 speeds, for hoist applications

4. *Données nominales*

- 4.1 *Moteurs triphasés, 1 vitesse*
- 4.2 *Moteurs triphasés, 2 vitesses, pour usage général*
- 4.3 *Moteurs triphasés, 1 vitesse, pour levage*
- 4.4 *Moteurs triphasés, 2 vitesses, pour levage*

4. Betriebsdaten

- 4.1 Drehstrom Motoren, 1 Drehzahl
- 4.2 Drehstrom Motoren, 2 Drehzahlen, für allgemeinen Gebrauch
- 4.3 Drehstrom Motoren, 1 Drehzahl, Hubmotoren
- 4.4 Drehstrom Motoren, 2 Drehzahlen, Hubmotoren

4. *Datos nominales*

- 4.1 *Motores trifásicos, 1 velocidad*
- 4.2 *Motores trifásicos, 2 velocidades, para uso general*
- 4.3 *Motores trifásicos, 1 velocidad, para elevación*
- 4.4 *Motores trifásicos, 2 velocidades, para elevación*

4. Dati nominali

- 4.1 Motori trifase, 1 velocità
- 4.2 Motori trifase, 2 velocità, per uso generale
- 4.3 Motori trifase, 1 velocità, per sollevamento
- 4.4 Motori trifase, 2 velocità, per sollevamento

GB	Three-phase motors	II 2G II 2GD	1	Speed	Duty type	S4 40%	Unventilated	Ventilated
F	Moteurs triphasés			Vitesse	Service type		Non ventilés	Ventilés
D	Drehstrom Motoren			Drehzahl	Betrieb		Unbelüftet	Belüftet
E	Motores trifásicos			Velocidad	Régimen		No ventilados	Ventilados
I	Motori trifase			Velocità	Servizio tipo		Non ventilati	Ventilati

Motor type	Rated output	Speed	Current	Efficiency	Power factor	Torque
Moteur type	Puissance	Vitesse	Intensité	Rendement	Facteur de puissance	Couple
Motor Typ	Leistung	Drehzahl	Strom	Wirkungsgrad	Leistungs-faktor	Moment
Tipo de motor	Potencia proporcionada	Velocidad	Corriente	Rendimiento	Factor de potencia	Par
Tipo motore	Potenza resa	Velocità	Corrente	Rendimento	Fattore potenza	Coppia

IIB		IIC		P _n [kW]	n [1/min]	I _n ^D [A]	η [%]	cos φ	M _n [Nm]
EEx-d	EEx-de	EEx-d	EEx-de						
DB30 63 A 2	DB35 63 A 2	DC30 63 A 2	DC35 63 A 2	0.18	2850	0.75	63	0.57	0.6
DB30 63 B 2	DB35 63 B 2	DC30 63 B 2	DC35 63 B 2	0.25	2805	0.85	66	0.66	0.9
(HB) DB30 71 A 2	(HB) DB35 71 A 2	(HC) DC30 71 A 2	(HC) DC35 71 A 2	0.37	2800	1.10	62	0.77	1.3
(HB) DB30 71 B 2	(HB) DB35 71 B 2	(HC) DC30 71 B 2	(HC) DC35 71 B 2	0.55	2830	1.40	71	0.79	1.9
(HB) DB30 80 A 2	(HB) DB35 80 A 2	(HC) DC30 80 A 2	(HC) DC35 80 A 2	0.75	2800	1.90	71	0.80	2.6
(HB) DB30 80 B 2	(HB) DB35 80 B 2	(HC) DC30 80 B 2	(HC) DC35 80 B 2	1.10	2830	2.60	78	0.78	3.7
(HB) DB30 90 S 2	(HB) DB35 90 S 2	(HC) DC30 90 S 2	(HC) DC35 90 S 2	1.50	2870	3.10	87	0.80	5.0
(HB) DB30 90 L 2	(HB) DB35 90 L 2	(HC) DC30 90 L 2	(HC) DC35 90 L 2	2.20	2860	4.80	81	0.82	7.3
(HB) DB30 100 LA 2	(HB) DB35 100 LA 2	(HC) DC30 100 LA 2	(HC) DC35 100 LA 2	3.00	2860	7.30	73	0.81	10.0
(HB) DB30 112 M 2	(HB) DB35 112 M 2	(HC) DC30 112 M 2	(HC) DC35 112 M 2	4.00	2900	8.70	80	0.83	13.2
(HB) DB30 132 SA 2	(HB) DB35 132 SA 2	(HC) DC30 132 SA 2	(HC) DC35 132 SA 2	5.50	2890	11.50	79	0.87	18.2
(HB) DB30 132 SB 2	(HB) DB35 132 SB 2	(HC) DC30 132 SB 2	(HC) DC35 132 SB 2	7.50	2910	15.00	81	0.89	24.6
(HB) DB30 132 MB 2	(HB) DB35 132 MB 2	(HC) DC30 132 MB 2	(HC) DC35 132 MB 2	9.20	2900	18.00	84	0.88	30.3
(HB) DB30 132 ML 2	(HB) DB35 132 ML 2	(HC) DC30 132 ML 2	(HC) DC35 132 ML 2	11.00	2929	20.00	92	0.86	35.9
(HB) DB30 160 MA 2	(HB) DB35 160 MA 2	(HC) DC30 160 MA 2	(HC) DC35 160 MA 2	11.00	2940	22.70	83	0.84	35.9
(HB) DB30 160 MB 2	(HB) DB35 160 MB 2	(HC) DC30 160 MB 2	(HC) DC35 160 MB 2	15.00	2940	29.50	82	0.90	48.7
(HB) DB30 160 L 2	(HB) DB35 160 L 2	(HC) DC30 160 L 2	(HC) DC35 160 L 2	18.50	2950	35.00	90	0.85	59.9

DB, DC

Unventilated S4 40%;
Non ventilés S4 40%;
Unbelüftet S4 40%;
No ventilados S4 40%;
Non ventilati S4 40%;

HB, HC

Axis height 71 S1 ventilated;
Ventilés S1 avec hauteur d'axe de 71;
Belüftet S1 von Baugröße 71;
Ventilados S1 con altura del eje 71;
Ventilati S1 da altezza d'asse 71;

$$I_n^D = I_n \cdot \frac{400}{U}$$

(I_n = current at U' Volt);
(I_n = intensité à U' Volt);
(I_n = Strom mit U' Volt);
(I_n = corriente de U' Voltios);
(I_n = corrente a U' Volt);

Rated data at <i>Données nominales à</i> Betriebsdaten bei <i>Datos nominales</i> Dati nominali a			direct on line start <i>démarrage direct</i> Direkteinschaltung <i>arranque directo</i> avviamento diretto			Brake <i>Frein</i> Bremse <i>Freno</i> Freno		rpm <i>tours/min</i> U/min <i>rev/min</i> giri/min		GB F D E I
400 V 50 Hz								3000		
Starting current	Starting torque	Maximum torque	Sound pressure	Moment of inertia	Mass	Torque	Power	CESI Certificates	Class T	
<i>Intensité démarrage</i>	<i>Couple démarrage</i>	<i>Couple maximal</i>	<i>Pression sonore</i>	<i>Moment d'inertie</i>	<i>Masse</i>	<i>Couple</i>	<i>Puissance</i>	<i>CESI Certificat</i>	<i>Classe T</i>	
Anlaufstrom	Anlaufmoment	Kippmoment	Geräuschwerte	Trägheitsmoment	Masse	Moment	Leistung	CESI Konformitäts-Bescheinigung	Klasse T	
<i>Corriente de arranque</i>	<i>Par de arranque</i>	<i>Par máximo</i>	<i>Presión acústica</i>	<i>Momento de inercia</i>	<i>Peso</i>	<i>Par</i>	<i>Potencia</i>	<i>Certificados CESI</i>	<i>Clase T</i>	
Corrente avviamento	Coppia avviamento	Coppia massima	Pressione sonora	Momento d'inertzia	Massa	Coppia	Potenza	Certificato CESI	Classe T	
I_a/I_n	M_a/M_n	M_m/M_n	Lp [dB(A)]	J ▼ [kgm ²]	m [kg]	[Nm] ●	[VA]	IIB	IIC	◆
4.2	3.6	3.8	57	0.00015	22	4	40	03 ATEX 111	03 ATEX 110	4
4.1	3.5	3.7	57	0.00015	22	4	40	03 ATEX 111	03 ATEX 110	4
3.6	2.4	2.6	65	0.00082	29	9	50	03 ATEX 111	03 ATEX 110	4
4.3	2.5	2.7	65	0.00082	29	9	50	03 ATEX 111	03 ATEX 110	4
4.8	2.6	2.8	67	0.00140	36	17	60	03 ATEX 111	03 ATEX 110	4
5.2	2.8	2.9	67	0.00160	36	17	60	03 ATEX 111	03 ATEX 110	4
6.2	2.3	2.5	70	0.00230	52	35	140	03 ATEX 111	03 ATEX 110	4
6.4	2.8	3.0	70	0.00260	52	35	140	03 ATEX 111	02 ATEX 110	4
6.8	2.6	2.7	74	0.00422	62	48	180	03 ATEX 111	03 ATEX 110	4
7.0	2.3	2.5	74	0.00959	100	70	250	03 ATEX 113	03 ATEX 112	4
6.8	2.6	2.9	75	0.02056	124	90	400	03 ATEX 113	03 ATEX 112	4
7.0	2.8	3.0	75	0.02316	124	90	400	03 ATEX 113	03 ATEX 112	4
7.0	2.8	3.0	75	0.02596	134	90	400	03 ATEX 113	03 ATEX 112	4
6.9	2.8	3.1	75	0.02976	134	90	400	03 ATEX 113	03 ATEX 112	4
8.0	2.8	3.0	80	0.04101	217	130	480	03 ATEX 113	03 ATEX 112	4
8.5	3.0	3.4	80	0.05131	217	130	480	03 ATEX 113	03 ATEX 112	4
8.1	3.0	3.4	80	0.05841	230	130	480	03 ATEX 113	03 ATEX 112	4

$$J = \frac{PD^2}{4}$$

● For motors duty type S1 torque value to be reduced of 50%
Pour moteurs en service S1 réduire la couple donnée du 50%
für Motoren in Betrieb S1 Moment Werte Wird beim 50% reduziert
Para los motores en régimen S1 el dato de par es reducido del 50%
Per i motori con servizio S1 il valore di coppia è ridotto del 50%

◆ T3, T5 see table 1B;
T3, T5 voir tableau 1B;
T3, T5 siehe Tabelle 1B;
T3, T5 véase tabla 1B;
T3, T5 vedi tabella 1B;

GB	Three-phase motors	Speed	Duty type	Unventilated	Ventilated
F	Moteurs triphasés	Vitesse	Service type	Non ventilés	Ventilés
D	Drehstrom Motoren	Drehzahl	Betrieb	Unbelüftet	Belüftet
E	Motores trifásicos	Velocidad	Régimen	No ventilados	Ventilados
I	4.1 Motori trifase	1 Velocità	Servizio tipo	Non ventilati	Ventilati

II 2G
II 2GD

S4
40%

(S1)

Motor type	Rated output	Speed	Current	Efficiency	Power factor	Torque
Moteur type	Puissance	Vitesse	Intensité	Rendement	Facteur de puissance	Couple
Motor Typ	Leistung	Drehzahl	Strom	Wirkungsgrad	Leistungs-faktor	Moment
Tipo de motor	Potencia proporcionada	Velocidad	Corriente	Rendimiento	Factor de potencia	Par
Tipo motore	Potenza resa	Velocità	Corrente	Rendimento	Fattore potenza	Coppia

IIB		IIC		P _n [kW]	n [1/min]	I _n ^D [A]	η [%]	cos φ	M _n [Nm]
EEx-d	EEx-de	EEx-d	EEx-de						
DB30 63 A 4	DB35 63 A 4	DC30 63 A 4	DC35 63 A 4	0.12	1380	0.62	58	0.55	0.9
DB30 63 B 4	DB35 63 B 4	DC30 63 B 4	DC35 63 B 4	0.18	1340	0.67	59	0.65	1.3
(HB) DB30 71 A 4	(HB) DB35 71 A 4	(HC) DC30 71 A 4	(HC) DC35 71 A 4	0.25	1380	0.77	65	0.71	1.8
(HB) DB30 71 B 4	(HB) DB35 71 B 4	(HC) DC30 71 B 4	(HC) DC35 71 B 4	0.37	1380	1.10	69	0.72	2.6
(HB) DB30 80 A 4	(HB) DB35 80 A 4	(HC) DC30 80 A 4	(HC) DC35 80 A 4	0.55	1380	1.60	70	0.71	3.8
(HB) DB30 80 B 4	(HB) DB35 80 B 4	(HC) DC30 80 B 4	(HC) DC35 80 B 4	0.75	1400	2.00	77	0.70	5.1
(HB) DB30 90 S 4	(HB) DB35 90 S 4	(HC) DC30 90 S 4	(HC) DC35 90 S 4	1.10	1405	2.80	79	0.74	7.5
(HB) DB30 90 L 4	(HB) DB35 90 L 4	(HC) DC30 90 L 4	(HC) DC35 90 L 4	1.50	1420	3.60	76	0.79	10.2
(HB) DB30 100 LA 4	(HB) DB35 100 LA 4	(HC) DC30 100 LA 4	(HC) DC35 100 LA 4	2.20	1420	5.10	76	0.82	14.8
(HB) DB30 100 LB 4	(HB) DB35 100 LB 4	(HC) DC30 100 LB 4	(HC) DC35 100 LB 4	3.00	1430	6.90	85	0.74	20.0
(HB) DB30 112 M 4	(HB) DB35 112 M 4	(HC) DC30 112 M 4	(HC) DC35 112 M 4	4.00	1440	8.20	86	0.83	26.5
(HB) DB30 132 SB 4	(HB) DB35 132 SB 4	(HC) DC30 132 SB 4	(HC) DC35 132 SB 4	5.50	1455	11.60	88	0.78	36.2
(HB) DB30 132 MB 4	(HB) DB35 132 MB 4	(HC) DC30 132 MB 4	(HC) DC35 132 MB 4	7.50	1450	16.50	85	0.77	49.4
(HB) DB30 132 ML 4	(HB) DB35 132 ML 4	(HC) DC30 132 ML 4	(HC) DC35 132 ML 4	8.80	1455	18.50	87	0.79	57.8
(HB) DB30 160 MB 4	(HB) DB35 160 MB 4	(HC) DC30 160 MB 4	(HC) DC35 160 MB 4	11.00	1470	23.00	89	0.78	71.9
(HB) DB30 160 L 4	(HB) DB35 160 L 4	(HC) DC30 160 L 4	(HC) DC35 160 L 4	15.00	1470	30.00	92	0.79	97.4
PB30 180 M 4	PB35 180 M 4	PC30 180 M 4	PC35 180 M 4	18.50	1470	39.30	90	0.75	120.2
PB30 180 L 4	PB35 180 L 4	PC30 180 L 4	PC35 180 L 4	22.00	1470	44.00	92	0.78	143.9
PB30 200 LB 4	PB35 200 LB 4	PC30 200 LB 4	PC35 200 LB 4	30.00	1470	54.00	95	0.85	196.2
PB30 225 S 4	PB35 225 S 4	PC30 225 S 4	PC35 225 S 4	37.00	1480	70.00	94	0.81	239.5
PB30 225 M 4	PB35 225 M 4	PC30 225 M 4	PC35 225 M 4	45.00	1480	82.00	95	0.83	290.4

DB, DC - PB, PC
Unventilated S4 40%;
Non ventilés S4 40%;
Unbelüftet S4 40%;
No ventilados S4 40%;
Non ventilati S4 40%;

HB, HC
Axis height 71 S1 ventilated;
Ventilés S1 avec hauteur d'axe de 71;
Belüftet S1 von Baugröße 71;
Ventilados S1 con altura del eje 71;
Ventilati S1 da altezza d'asse 71;

$$I'_n = I_n \cdot \frac{400}{U}$$

(I'_n = current at U' Volt);
(I'_n = intensité à U' Volt);
(I'_n = Strom mit U' Volt);
(I'_n = corriente de U' Voltios);
(I'_n = corrente a U' Volt);

Rated data at <i>Données nominales à</i> Betriebsdaten bei <i>Datos nominales</i> Dati nominali a			direct on line start <i>démarrage direct</i> Direkteinschaltung <i>arranque directo</i> avviamento diretto			Brake <i>Frein</i> Bremse <i>Freno</i> Freno		rpm <i>tours/min</i> U/min <i>rev/min</i> giri/min		GB F D E I
400 V 50 Hz								1500		
Starting current	Starting torque	Maximum torque	Sound pressure	Moment of inertia	Mass	Torque	Power	CESI Certificates	Class T	
<i>Intensité démarrage</i>	<i>Couple démarrage</i>	<i>Couple maximal</i>	<i>Pression sonore</i>	<i>Moment d'inertie</i>	<i>Masse</i>	<i>Couple</i>	<i>Puissance</i>	<i>CESI Certificat</i>	<i>Classe T</i>	
Anlaufstrom	Anlaufmoment	Kippmoment	Geräuschwerte	Trägheitsmoment	Masse	Moment	Leistung	CESI Konformitäts-Bescheinigung	Klasse T	
<i>Corriente de arranque</i>	<i>Par de arranque</i>	<i>Par máximo</i>	<i>Presión acústica</i>	<i>Momento de inercia</i>	<i>Peso</i>	<i>Par</i>	<i>Potencia</i>	<i>Certificados CESI</i>	<i>Clase T</i>	
Corrente avviamento	Coppia avviamento	Coppia massima	Pressione sonora	Momento d'inertzia	Massa	Coppia	Potenza	Certificato CESI	Classe T	
I_a/I_n	M_a/M_n	M_m/M_n	Lp [dB(A)]	J ▼ [kgm ²]	m [kg]	[Nm] ●	[VA]	IIB	IIC	◆
2.9	2.3	2.5	45	0.00025	22	4	40	03 ATEX 111	03 ATEX 110	4
2.4	2.3	2.5	45	0.00025	22	4	40	03 ATEX 111	03 ATEX 110	4
3.1	2.2	2.6	49	0.00102	29	9	50	03 ATEX 111	03 ATEX 110	4
3.5	2.2	2.7	49	0.00132	29	9	50	03 ATEX 111	03 ATEX 110	4
4.0	2.3	2.5	52	0.00170	36	17	60	03 ATEX 111	03 ATEX 110	4
4.0	2.3	2.6	52	0.00210	36	17	60	03 ATEX 111	03 ATEX 110	4
4.0	2.0	2.4	58	0.00310	52	35	140	03 ATEX 111	03 ATEX 110	4
4.8	2.3	2.5	58	0.00370	52	35	140	03 ATEX 111	03 ATEX 110	4
5.9	2.5	2.7	61	0.00562	62	48	180	03 ATEX 111	03 ATEX 110	4
6.5	2.6	2.9	61	0.00662	62	48	180	03 ATEX 111	03 ATEX 110	4
5.5	2.1	2.9	64	0.01249	100	70	250	03 ATEX 113	03 ATEX 112	4
6.2	2.4	2.8	68	0.03316	134	90	400	03 ATEX 113	03 ATEX 112	4
6.7	2.5	3.4	68	0.04056	134	90	400	03 ATEX 113	03 ATEX 112	4
6.8	2.5	3.5	68	0.04866	134	90	400	03 ATEX 113	03 ATEX 112	4
5.6	2.5	3.0	70	0.06771	217	130	480	03 ATEX 113	03 ATEX 112	4
5.9	2.5	3.0	70	0.08511	217	130	480	03 ATEX 113	03 ATEX 112	4
6.1	3.2	3.0	71	0.17900	280	250	670	02 ATEX 032	02 ATEX 033	4
7.0	2.3	2.3	71	0.20080	280	250	670	02 ATEX 032	02 ATEX 033	4
6.6	2.7	2.9	73	0.29560	355	320	670	02 ATEX 032	02 ATEX 033	4
7.0	2.7	3.0	74	0.42820	400	320	670	02 ATEX 032	02 ATEX 033	4
6.1	2.4	2.7	74	0.49710	450	320	670	02 ATEX 032	02 ATEX 033	4

$$J = \frac{PD^2}{4}$$

● For motors duty type S1 torque value to be reduced of 50%
Pour moteurs en service S1 réduire la couple donnée du 50%
für Motoren in Betrieb S1 Moment Werte Wird beim 50% reduziert
Para los motores en régimen S1 el dato de par es reducido del 50%
Per i motori con servizio S1 il valore di coppia è ridotto del 50%

◆ T3, T5 see table 1B;
T3, T5 voir tableau 1B;
T3, T5 siehe Tabelle 1B;
T3, T5 véase tabla 1B;
T3, T5 vedi tabella 1B;

GB	Three-phase motors	Speed	Duty type	Unventilated	Ventilated
F	<i>Moteurs triphasés</i>	<i>Vitesse</i>	<i>Service type</i>	<i>Non ventilés</i>	<i>Ventilés</i>
D	Drehstrom Motoren	Drehzahl	Betrieb	Unbelüftet	Belüftet
E	<i>Motores trifásicos</i>	<i>Velocidad</i>	<i>Régimen</i>	<i>No ventilados</i>	<i>Ventilados</i>
I	4.1 Motori trifase	1 Velocità	Servizio tipo	Non ventilati	(S1) Ventilati

Motor type	Rated output	Speed	Current	Efficiency	Power factor	Torque
<i>Moteur type</i>	<i>Puissance</i>	<i>Vitesse</i>	<i>Intensité</i>	<i>Rendement</i>	<i>Facteur de puissance</i>	<i>Couple</i>
Motor Typ	Leistung	Drehzahl	Strom	Wirkungsgrad	Leistungs-faktor	Moment
<i>Tipo de motor</i>	<i>Potencia proporcionada</i>	<i>Velocidad</i>	<i>Corriente</i>	<i>Rendimiento</i>	<i>Factor de potencia</i>	<i>Par</i>
Tipo motore	Potenza resa	Velocità	Corrente	Rendimento	Fattore potenza	Coppia

IIB		IIC		P _n [kW]	n [1/min]	I _n [●] [A]	η [%]	cos φ	M _n [Nm]
EEx-d	EEx-de	EEx-d	EEx-de						
DB30 63 B 6	DB35 63 B 6	DC30 63 B 6	DC35 63 B 6	0.09	860	0.65	38	0.52	1.0
(HB) DB30 71 A 6	(HB) DB35 71 A 6	(HC) DC30 71 A 6	(HC) DC35 71 A 6	0.18	930	1.10	51	0.58	1.8
(HB) DB30 71 B 6	(HB) DB35 71 B 6	(HC) DC30 71 B 6	(HC) DC35 71 B 6	0.26	925	1.20	56	0.58	2.8
(HB) DB30 80 A 6	(HB) DB35 80 A 6	(HC) DC30 80 A 6	(HC) DC35 80 A 6	0.37	930	1.60	57	0.58	3.8
(HB) DB30 80 B 6	(HB) DB35 80 B 6	(HC) DC30 80 B 6	(HC) DC35 80 B 6	0.55	930	1.80	70	0.65	5.6
(HB) DB30 90 S 6	(HB) DB35 90 S 6	(HC) DC30 90 S 6	(HC) DC35 90 S 6	0.75	910	2.20	70	0.71	7.8
(HB) DB30 90 L 6	(HB) DB35 90 L 6	(HC) DC30 90 L 6	(HC) DC35 90 L 6	1.10	935	3.20	86	0.59	11.2
(HB) DB30 100 LB 6	(HB) DB35 100 LB 6	(HC) DC30 100 LB 6	(HC) DC35 100 LB 6	1.50	950	3.80	76	0.75	15.1
(HB) DB30 112 M 6	(HB) DB35 112 M 6	(HC) DC30 112 M 6	(HC) DC35 112 M 6	2.20	960	5.50	81	0.71	22.3
(HB) DB30 132 SB 6	(HB) DB35 132 SB 6	(HC) DC30 132 SB 6	(HC) DC35 132 SB 6	3.00	950	8.50	71	0.72	30.2
(HB) DB30 132 MB 6	(HB) DB35 132 MB 6	(HC) DC30 132 MB 6	(HC) DC35 132 MB 6	4.00	970	9.50	81	0.75	39.4
(HB) DB30 132 ML 6	(HB) DB35 132 ML 6	(HC) DC30 132 ML 6	(HC) DC35 132 ML 6	5.50	960	12.00	86	0.77	54.7
(HB) DB30 160 MB 6	(HB) DB35 160 MB 6	(HC) DC30 160 MB 6	(HC) DC35 160 MB 6	7.50	950	16.00	84	0.81	75.4
(HB) DB30 160 L 6	(HB) DB35 160 L 6	(HC) DC30 160 L 6	(HC) DC35 160 L 6	11.00	950	23.00	81	0.85	110.6
PB30 180 L 6	PB35 180 L 6	PC30 180 L 6	PC35 180 L 6	15.00	960	28.50	88	0.86	149.2
PB30 200 LA 6	PB35 200 LA 6	PC30 200 LA 6	PC35 200 LA 6	18.50	975	38.20	91	0.77	182.1
PB30 200 LB 6	PB35 200 LB 6	PC30 200 LB 6	PC35 200 LB 6	22.00	980	43.80	92	0.78	215.5
PB30 225 M 6	PB35 225 M 6	PC30 225 M 6	PC35 225 M 6	30.00	985	60.50	92	0.78	290.8

DB, DC - PB, PC
Unventilated S4 40%;
Non ventilés S4 40%;
Unbelüftet S4 40%;
No ventilados S4 40%;
Non ventilati S4 40%;

HB, HC
Axis height 71 S1 ventilated;
Ventilés S1 avec hauteur d'axe de 71;
Belüftet S1 von Baugröße 71;
Ventilados S1 con altura del eje 71;
Ventilati S1 da altezza d'asse 71;

$$I'_n = I_n \cdot \frac{400}{U}$$

(I'_n = current at U' Volt);
(I'_n = intensité à U' Volt);
(I'_n = Strom mit U' Volt);
(I'_n = corriente de U' Voltios);
(I'_n = corrente a U' Volt);

Rated data at <i>Données nominales à</i> Betriebsdaten bei <i>Datos nominales</i> Dati nominali a			direct on line start <i>démarrage direct</i> Direkteinschaltung <i>arranque directo</i> avviamento diretto			Brake <i>Frein</i> Bremse <i>Freno</i> Freno		rpm <i>tours/min</i> U/min <i>rev/min</i> giri/min		GB F D E I
400 V 50 Hz								1000		
Starting current	Starting torque	Maximum torque	Sound pressure	Moment of inertia	Mass	Torque	Power	CESI Certificates	Class T	
<i>Intensité démarrage</i>	<i>Couple démarrage</i>	<i>Couple maximal</i>	<i>Pression sonore</i>	<i>Moment d'inertie</i>	<i>Masse</i>	<i>Couple</i>	<i>Puissance</i>	<i>CESI Certificat</i>	<i>Classe T</i>	
Anlaufstrom	Anlaufmoment	Kippmoment	Geräuschwerte	Trägheitsmoment	Masse	Moment	Leistung	CESI Konformitäts-Bescheinigung	Klasse T	
<i>Corriente de arranque</i>	<i>Par de arranque</i>	<i>Par máximo</i>	<i>Presión acústica</i>	<i>Momento de inercia</i>	<i>Peso</i>	<i>Par</i>	<i>Potencia</i>	<i>Certificados CESI</i>	<i>Clase T</i>	
Corrente avviamento	Coppia avviamento	Coppia massima	Pressione sonora	Momento d'inerzia	Massa	Coppia	Potenza	Certificato CESI	Classe T	
I_a/I_n	M_a/M_n	M_m/M_n	Lp [dB(A)]	J ▼ [kgm ²]	m [kg]	[Nm] ●	[VA]	IIB	IIC	◆
2.0	2.0	1.9	42	0.00025	22	4	40	03 ATEX 111	03 ATEX 110	4
2.2	2.0	1.8	48	0.00112	29	9	50	03 ATEX 111	03 ATEX 110	4
2.3	2.0	1.8	48	0.00142	29	9	50	03 ATEX 111	03 ATEX 110	4
3.1	2.9	3.2	49	0.00300	36	17	60	03 ATEX 111	03 ATEX 110	4
2.8	2.0	2.1	49	0.00350	36	17	60	03 ATEX 111	03 ATEX 110	4
3.0	1.8	2.1	53	0.00450	52	35	140	03 ATEX 111	03 ATEX 110	4
3.4	2.0	2.2	53	0.00600	52	35	140	03 ATEX 111	03 ATEX 110	4
3.8	1.7	2.1	55	0.01012	62	48	180	03 ATEX 111	03 ATEX 110	4
4.7	1.8	2.1	57	0.01939	100	70	250	03 ATEX 113	03 ATEX 112	4
4.6	1.7	2.1	60	0.04046	134	90	400	03 ATEX 113	03 ATEX 112	4
4.6	1.7	2.1	60	0.04766	134	90	400	03 ATEX 113	03 ATEX 112	4
4.7	1.8	2.2	60	0.05876	134	90	400	03 ATEX 113	03 ATEX 112	4
4.6	1.8	2.4	64	0.09691	217	130	480	03 ATEX 113	03 ATEX 112	4
4.7	1.7	2.3	64	0.12681	217	130	480	03 ATEX 113	03 ATEX 112	4
5.2	1.7	2.2	67	0.25870	280	250	670	02 ATEX 032	02 ATEX 033	4
5.9	1.6	2.1	69	0.35060	355	320	670	02 ATEX 032	02 ATEX 033	4
6.2	1.6	2.1	69	0.40230	355	320	670	02 ATEX 032	02 ATEX 033	4
6.5	2.1	2.6	70	0.74850	450	320	670	02 ATEX 032	02 ATEX 033	4

$$J = \frac{PD^2}{4}$$

● For motors duty type S1 torque value to be reduced of 50%
Pour moteurs en service S1 réduire la couple donnée du 50%
für Motoren in Betrieb S1 Moment Werte Wird beim 50% reduziert
Para los motores en régimen S1 el dato de par es reducido del 50%
Per i motori con servizio S1 il valore di coppia è ridotto del 50%

◆ T3, T5 see table 1B;
T3, T5 voir tableau 1B;
T3, T5 siehe Tabelle 1B;
T3, T5 véase tabla 1B;
T3, T5 vedi tabella 1B;

GB	Three-phase motors	Speed	Duty type	Unventilated	Ventilated
F	Moteurs triphasés	Vitesse	Service type	Non ventilés	Ventilés
D	Drehstrom Motoren	Drehzahl	Betrieb	Unbelüftet	Belüftet
E	Motores trifásicos	Velocidad	Régimen	No ventilados	Ventilados
I	Motori trifase	Velocità	Servizio tipo	Non ventilati	Ventilati

4.
4.1

II 2G
II 2GD

1

S4
40%

(S1)

Motor type	Rated output	Speed	Current	Efficiency	Power factor	Torque
Moteur type	Puissance	Vitesse	Intensité	Rendement	Facteur de puissance	Couple
Motor Typ	Leistung	Drehzahl	Strom	Wirkungsgrad	Leistungs-faktor	Moment
Tipo de motor	Potencia proporcionada	Velocidad	Corriente	Rendimiento	Factor de potencia	Par
Tipo motore	Potenza resa	Velocità	Corrente	Rendimento	Fattore potenza	Coppia

IIB		IIC		P _n [kW]	n [1/min]	I _n [▶] [A]	η [%]	cos φ	M _n [Nm]
EEx-d	EEx-de	EEx-d	EEx-de						
DB30 63 B 8	DB35 63 B 8	DC30 63 B 8	DC35 63 B 8	0.05	590	0.44	27	0.60	0.8
(HB) DB30 71 B 8	(HB) DB35 71 B 8	(HC) DC30 71 B 8	(HC) DC35 71 B 8	0.15	600	0.57	51	0.75	2.4
(HB) DB30 80 A 8	(HB) DB35 80 A 8	(HC) DC30 80 A 8	(HC) DC35 80 A 8	0.18	680	0.86	52	0.58	2.5
(HB) DB30 80 B 8	(HB) DB35 80 B 8	(HC) DC30 80 B 8	(HC) DC35 80 B 8	0.25	690	1.00	60	0.60	3.5
(HB) DB30 90 S 8	(HB) DB35 90 S 8	(HC) DC30 90 S 8	(HC) DC35 90 S 8	0.37	680	1.30	75	0.55	5.2
(HB) DB30 90 L 8	(HB) DB35 90 L 8	(HC) DC30 90 L 8	(HC) DC35 90 L 8	0.55	680	1.90	80	0.52	7.7
(HB) DB30 100 LA 8	(HB) DB35 100 LA 8	(HC) DC30 100 LA 8	(HC) DC35 100 LA 8	0.75	720	2.90	67	0.56	9.9
(HB) DB30 100 LB 8	(HB) DB35 100 LB 8	(HC) DC30 100 LB 8	(HC) DC35 100 LB 8	1.10	675	3.10	75	0.68	15.6
(HB) DB30 112 M 8	(HB) DB35 112 M 8	(HC) DC30 112 M 8	(HC) DC35 112 M 8	1.50	715	4.40	76	0.65	20.0
(HB) DB30 132 SB 8	(HB) DB35 132 SB 8	(HC) DC30 132 SB 8	(HC) DC35 132 SB 8	2.20	720	6.50	75	0.67	30.0
(HB) DB30 132 ML 8	(HB) DB35 132 ML 8	(HC) DC30 132 ML 8	(HC) DC35 132 ML 8	3.00	720	8.00	75	0.72	39.8
(HB) DB30 160 MA 8	(HB) DB35 160 MA 8	(HC) DC30 160 MA 8	(HC) DC35 160 MA 8	4.00	730	10.50	74	0.74	52.3
(HB) DB30 160 MB 8	(HB) DB35 160 MB 8	(HC) DC30 160 MB 8	(HC) DC35 160 MB 8	5.50	725	13.50	76	0.77	72.4
(HB) DB30 160 L 8	(HB) DB35 160 L 8	(HC) DC30 160 L 8	(HC) DC35 160 L 8	7.50	720	17.50	80	0.77	99.5
PB30 180 L 8	PB35 180 L 8	PC30 180 L 8	PC35 180 L 8	11.00	720	23.00	87	0.79	145.9
PB30 200 LB 8	PB35 200 LB 8	PC30 200 LB 8	PC35 200 LB 8	15.00	735	35.20	89	0.70	196.2
PB30 225 S 8	PB35 225 S 8	PC30 225 S 8	PC35 225 S 8	18.50	730	38.50	88	0.79	242.0
PB30 225 M 8	PB35 225 M 8	PC30 225 M 8	PC35 225 M 8	22.00	730	45.50	88	0.79	287.8

DB, DC - PB, PC
Unventilated S4 40%;
Non ventilés S4 40%;
Unbelüftet S4 40%;
No ventilados S4 40%;
Non ventilati S4 40%;

HB, HC
Axis height 71 S1 ventilated;
Ventilés S1 avec hauteur d'axe de 71;
Belüftet S1 von Baugröße 71;
Ventilados S1 con altura del eje 71;
Ventilati S1 da altezza d'asse 71;

$$I_n^{\blacktriangleright} = I_n \cdot \frac{400}{U}$$

(I_n = current at U' Volt);
(I_n = intensité à U' Volt);
(I_n = Strom mit U' Volt);
(I_n = corriente de U' Voltios);
(I_n = corrente a U' Volt);

Rated data at <i>Données nominales à</i> Betriebsdaten bei <i>Datos nominales</i> Dati nominali a			direct on line start <i>démarrage direct</i> Direkteinschaltung <i>arranque directo</i> avviamento diretto			Brake <i>Frein</i> Bremse <i>Freno</i> Freno		rpm <i>tours/min</i> U/min <i>rev/min</i> giri/min		GB F D E I
400 V 50 Hz								750		
Starting current	Starting torque	Maximum torque	Sound pressure	Moment of inertia	Mass	Torque	Power	CESI Certificates		Class T
<i>Intensité démarrage</i>	<i>Couple démarrage</i>	<i>Couple maximal</i>	<i>Pression sonore</i>	<i>Moment d'inertie</i>	<i>Masse</i>	<i>Couple</i>	<i>Puissance</i>	<i>CESI Certificat</i>		<i>Classe T</i>
Anlaufstrom	Anlaufmoment	Kippmoment	Geräuschwerte	Trägheitsmoment	Masse	Moment	Leistung	CESI Konformitäts-Bescheinigung		Klasse T
<i>Corriente de arranque</i>	<i>Par de arranque</i>	<i>Par máximo</i>	<i>Presión acústica</i>	<i>Momento de inercia</i>	<i>Peso</i>	<i>Par</i>	<i>Potencia</i>	<i>Certificados CESI</i>		<i>Clase T</i>
Corrente avviamento	Coppia avviamento	Coppia massima	Pressione sonora	Momento d'inerzia	Massa	Coppia	Potenza	Certificato CESI		Classe T
I_a/I_n	M_a/M_n	M_m/M_n	Lp [dB(A)]	J ▼ [kgm ²]	m [kg]	[Nm] ●	[VA]	IIB	IIC	◆
2.0	1.6	1.8	40	0.00025	22	4	40	03 ATEX 111	03 ATEX 110	4
2.0	1.3	1.5	40	0.00142	29	9	50	03 ATEX 111	03 ATEX 110	4
2.0	1.4	1.7	42	0.00300	36	17	60	03 ATEX 111	03 ATEX 110	4
2.3	1.4	1.7	42	0.00350	36	17	60	03 ATEX 111	03 ATEX 110	4
2.2	1.5	1.8	50	0.00450	52	35	140	03 ATEX 111	03 ATEX 110	4
2.1	1.5	1.8	50	0.00600	52	35	140	03 ATEX 111	03 ATEX 110	4
3.4	2.0	2.2	52	0.01012	62	48	180	03 ATEX 111	03 ATEX 110	4
2.7	1.8	2.2	52	0.01012	62	48	18	03 ATEX 111	03 ATEX 110	4
4.1	1.9	2.2	54	0.01939	100	70	250	03 ATEX 113	03 ATEX 112	4
3.9	1.8	2.3	58	0.04046	134	90	400	03 ATEX 113	03 ATEX 112	4
4.1	1.8	2.3	58	0.05876	134	90	400	03 ATEX 113	03 ATEX 112	4
4.0	2.0	2.6	62	0.09691	217	130	480	03 ATEX 113	03 ATEX 112	4
4.1	2.2	2.7	62	0.09691	217	130	480	03 ATEX 113	03 ATEX 112	4
4.3	2.4	2.8	62	0.12681	217	130	480	03 ATEX 113	03 ATEX 112	4
5.0	2.2	2.4	64	0.25870	280	250	670	02 ATEX 032	02 ATEX 033	4
5.3	1.6	2.1	65	0.40230	355	320	670	02 ATEX 032	02 ATEX 033	4
5.0	2.1	2.2	68	0.74850	400	320	670	02 ATEX 032	02 ATEX 033	4
5.0	2.1	2.3	68	0.74850	450	320	670	02 ATEX 032	02 ATEX 033	4

$$J = \frac{PD^2}{4}$$

● For motors duty type S1 torque value to be reduced of 50%
Pour moteurs en service S1 réduire la couple donnée du 50%
für Motoren in Betrieb S1 Moment Werte Wird beim 50% reduziert
Para los motores en régimen S1 el dato de par es reducido del 50%
Per i motori con servizio S1 il valore di coppia è ridotto del 50%

◆ T3, T5 see table 1B;
T3, T5 voir tableau 1B;
T3, T5 siehe Tabelle 1B;
T3, T5 véase tabla 1B;
T3, T5 vedi tabella 1B;

GB	Three-phase motors	II 2G II 2GD	2	Speeds, for general purpose	Duty type	S4 40%	Unventilated	Ventilated
F	Moteurs triphasés			Vitesses, pour usage général	Service type		Non ventilés	Ventilés
D	Drehstrom Motoren			Drehzahlen, für allgemeinen Gebrauch	Betrieb		Unbelüftet	Belüftet
E	Motores trifásicos			Velocidades, para uso general	Régimen		No ventilados	Ventilados
I	Motori trifase			Velocità, per uso generale	Servizio tipo		Non ventilati	Ventilati

Motor type	Rated output	Speed	Current	Efficiency	Power factor	Torque
Moteur type	Puissance	Vitesse	Intensité	Rendement	Facteur de puissance	Couple
Motor Typ	Leistung	Drehzahl	Strom	Wirkungsgrad	Leistungs-faktor	Moment
Tipo de motor	Potencia proporcionada	Velocidad	Corriente	Rendimiento	Factor de potencia	Par
Tipo motore	Potenza resa	Velocità	Corrente	Rendimento	Fattore potenza	Coppia

IIB		IIC		P _n [kW]	n [1/min]	I _n ^Δ [A]	η [%]	cos φ	M _n [Nm]
EEx-d	EEx-de	EEx-d	EEx-de						
DB20 63 B 24	DB25 63 B 24	DC20 63 B 24	DC25 63 B 24	0.20 0.15	2700 1340	0.76 0.67	54 46	0.70 0.70	0.7 1.1
(HB) DB20 71 A 24	(HB) DB25 71 A 24	(HC) DC20 71 A 24	(HC) DC25 71 A 24	0.30 0.20	2820 1360	0.86 0.76	71 54	0.71 0.70	1.0 1.4
(HB) DB20 71 B 24	(HB) DB25 71 B 24	(HC) DC20 71 B 24	(HC) DC25 71 B 24	0.45 0.30	2820 1360	1.20 0.95	69 63	0.78 0.72	1.5 2.1
(HB) DB20 80 A 24	(HB) DB25 80 A 24	(HC) DC20 80 A 24	(HC) DC25 80 A 24	0.60 0.45	2810 1350	1.50 1.20	76 75	0.76 0.72	2.0 3.2
(HB) DB20 80 B 24	(HB) DB25 80 B 24	(HC) DC20 80 B 24	(HC) DC25 80 B 24	0.80 0.60	2800 1400	2.10 1.70	65 72	0.85 0.71	2.7 4.1
(HB) DB20 90 S 24	(HB) DB25 90 S 24	(HC) DC20 90 S 24	(HC) DC25 90 S 24	1.25 0.90	2780 1380	2.90 2.40	65 64	0.96 0.85	4.3 6.2
(HB) DB20 90 L 24	(HB) DB25 90 L 24	(HC) DC20 90 L 24	(HC) DC25 90 L 24	1.60 1.20	2800 1400	3.60 2.90	71 78	0.90 0.77	5.5 8.2
(HB) DB20 100 LA 24	(HB) DB25 100 LA 24	(HC) DC20 100 LA 24	(HC) DC25 100 LA 24	2.35 1.85	2780 1400	5.40 4.50	70 72	0.90 0.82	8.1 12.6
(HB) DB20 100 LB 24	(HB) DB25 100 LB 24	(HC) DC20 100 LB 24	(HC) DC25 100 LB 24	3.00 2.40	2900 1420	7.40 5.60	78 81	0.76 0.77	10.0 16.1
(HB) DB20 112 M 24	(HB) DB25 112 M 24	(HC) DC20 112 M 24	(HC) DC25 112 M 24	4.00 3.30	2860 1450	8.60 6.80	84 65	0.80 0.80	13.4 21.7
(HB) DB20 132 S 24	(HB) DB25 132 S 24	(HC) DC20 132 S 24	(HC) DC25 132 S 24	5.90 4.80	2880 1430	11.50 10.00	80 82	0.93 0.85	19.6 32.1
(HB) DB20 132 M 24	(HB) DB25 132 M 24	(HC) DC20 132 M 24	(HC) DC25 132 M 24	7.50 5.50	2880 1430	14.50 13.50	88 73	0.85 0.80	24.9 44.1
(HB) DB20 132 L 24	(HB) DB25 132 L 24	(HC) DC20 132 L 24	(HC) DC25 132 L 24	8.00 6.00	2890 1440	19.00 17.00	72 63	0.85 0.80	30.4 49.7
(HB) DB20 160 M 24	(HB) DB25 160 M 24	(HC) DC20 160 M 24	(HC) DC25 160 M 24	11.00 8.80	2940 1440	22.00 22.00	80 78	0.90 0.74	35.7 58.4
(HB) DB20 160 L 24	(HB) DB25 160 L 24	(HC) DC20 160 L 24	(HC) DC25 160 L 24	15.00 12.00	2945 1450	29.50 28.50	77 81	0.95 0.75	48.6 79.0
PB20 180 M 24	PB25 180 M 24	PC20 180 M 24	PC25 180 M 24	18.50 15.00	2930 1460	36.00 29.50	83 83	0.90 0.88	60.3 98.1
PB20 180 L 24	PB25 180 L 24	PC20 180 L 24	PC25 180 L 24	22.00 18.50	2920 1460	40.00 35.50	86 91	0.92 0.83	71.9 121.0
PB20 200 LB 24	PB25 200 LB 24	PC20 200 LB 24	PC25 200 LB 24	30.00 24.00	2950 1470	56.00 43.50	87 91	0.89 0.88	97.1 155.9
PB20 225 S 24	PB25 225 S 24	PC20 225 S 24	PC25 225 S 24	33.00 30.00	2955 1475	66.00 55.00	80 91	0.90 0.87	106.6 194.2
PB20 225 M 24	PB25 225 M 24	PC20 225 M 24	PC25 225 M 24	40.00 37.00	2965 1480	77.00 69.00	82 88	0.92 0.88	128.8 238.7

DB, DC - PB, PC
 Unventilated S4 40%;
 Non ventilés S4 40%;
 Unbelüftet S4 40%;
 No ventilados S4 40%;
 Non ventilati S4 40%;

HB, HC
 Axis height 71 S1 ventilated;
 Ventilés S1 avec hauteur d'axe de 71;
 Belüftet S1 von Baugröße 71;
 Ventilados S1 con altura del eje 71;
 Ventilati S1 da altezza d'asse 71;

$$I'_n = I_n \cdot \frac{400}{U'}$$

(I'_n = current at U' Volt);
 (I'_n = intensité à U' Volt);
 (I'_n = Strom mit U' Volt);
 (I'_n = corriente de U' Voltios);
 (I'_n = corrente a U' Volt);

Rated data at <i>Données nominales à</i> Betriebsdaten bei <i>Datos nominales</i> Dati nominali a		400 V 50 Hz	direct on line start <i>démarrage direct</i> Direkteinschaltung <i>arranque directo</i> avviamento diretto			Brake <i>Frein</i> Bremse <i>Freno</i> Freno		3000 1500	rpm <i>tours/min</i> U/min <i>rev/min</i> giri/min		GB F D E I
Starting current	Starting torque		Sound pressure	Moment of inertia	Mass	Torque	Power		CESI Certificates	Class T	
<i>Intensité démarrage</i>	<i>Couple démarrage</i>		<i>Pression sonore</i>	<i>Moment d'inertie</i>	<i>Masse</i>	<i>Couple</i>	<i>Puissance</i>		<i>CESI Certificat</i>	<i>Classe T</i>	
Anlaufstrom	Anlaufmoment		Geräuschwerte	Trägheitsmoment	Masse	Moment	Leistung		CESI Konformitäts-Bescheinigung	Klasse T	
<i>Corriente de arranque</i>	<i>Par de arranque</i>		<i>Presión acústica</i>	<i>Momento de inercia</i>	<i>Peso</i>	<i>Par</i>	<i>Potencia</i>		<i>Certificados CESI</i>	<i>Clase T</i>	
Corrente avviamento	Coppia avviamento	Pressione sonora	Momento d'inertzia	Massa	Coppia	Potenza	Certificato CESI	Classe T			
I_a/I_n	M_a/M_n	Lp [dB(A)]	J ▼ [kgm ²]	m [kg]	[Nm] ●	[VA]	IIB	IIC	◆		
3.4 2.9	1.7 1.7	57	0.00025	22	4	40	03 ATEX 111	03 ATEX 110	4		
3.2 2.9 3.8 3.6	1.7 1.5 1.8 1.6	65	0.00102	29	9	50	03 ATEX 111	03 ATEX 110	4		
4.1 3.9 4.4 4.1	1.7 1.7 1.8 1.7	67	0.00170	36	17	60	03 ATEX 111	03 ATEX 110	4		
5.4 4.6 4.3 4.3	2.0 1.8 2.2 2.1	70	0.00310	52	35	140	03 ATEX 111	03 ATEX 110	4		
6.4 5.4 6.9 6.0	2.4 2.1 2.3 2.0	74	0.00562	62	48	180	03 ATEX 111	03 ATEX 110	4		
7.0 6.2	2.3 2.2	74	0.01249	100	70	250	03 ATEX 113	03 ATEX 112	4		
7.2 6.4 7.4 6.6 7.5 6.3	2.2 2.1 2.2 2.1 2.3 2.2	75	0.02316	134	90	400	03 ATEX 113	03 ATEX 112	4		
7.3 6.5 7.5 6.6	2.3 2.1 2.4 2.3	80	0.00671	217	130	480	03 ATEX 113	03 ATEX 112	4		
6.4 5.6 6.6 5.8	2.1 2.0 2.2 2.1	80	0.17900	280	250	670	02 ATEX 032	02 ATEX 033	4		
7.0 6.4	2.3 2.3	78	0.29560	355	320	670	02 ATEX 032	02 ATEX 033	4		
6.8 6.2 6.8 6.2	2.2 2.1 2.2 2.2	80	0.42820	400	320	670	02 ATEX 032	02 ATEX 033	4		
		80	0.49710	450	320	670	02 ATEX 032	02 ATEX 033	4		

$$J = \frac{PD^2}{4}$$

● For motors duty type S1 torque value to be reduced of 50%
Pour moteurs en service S1 réduire la couple donnée du 50%
Pour moteurs en service S1 réduire la couple donnée du 50%
Para los motores en régimen S1 el dato de par es reducido del 50%
 Per i motori con servizio S1 il valore di coppia è ridotto del 50%

◆ T3, T5 see table 1B;
T3, T5 voir tableau 1B;
T3, T5 siehe Tabelle 1B;
T3, T5 véase tabla 1B;
 T3, T5 vedi tabella 1B;

GB	Three-phase motors	II 2G II 2GD	Speeds, for general purpose	Duty type	S4 40%	Unventilated	Ventilated
F	Moteurs triphasés		Vitesses, pour usage général	Service type		Non ventilés	Ventilés
D	Drehstrom Motoren		Drehzahlen, für allgemeinen Gebrauch	Betrieb		Unbelüftet	Belüftet
E	Motores trifásicos		Velocidades, para uso general	Régimen		No ventilados	Ventilados
I	Motori trifase		Velocità, per uso generale	Servizio tipo		Non ventilati	Ventilati

Motor type	Rated output	Speed	Current	Efficiency	Power factor	Torque
Moteur type	Puissance	Vitesse	Intensité	Rendement	Facteur de puissance	Couple
Motor Typ	Leistung	Drehzahl	Strom	Wirkungsgrad	Leistungs-faktor	Moment
Tipo de motor	Potencia proporcionada	Velocidad	Corriente	Rendimiento	Factor de potencia	Par
Tipo motore	Potenza resa	Velocità	Corrente	Rendimento	Fattore potenza	Coppia

IIB		IIC		P _n [kW]	n [1/min]	I _n [●] [A]	η [%]	cos φ	M _n [Nm]
EEx-d	EEx-de	EEx-d	EEx-de						
(HB) DB20 71 A 48	(HB) DB25 71 A 48	(HC) DC20 71 A 48	(HC) DC25 71 A 48	0.17	1330	0.57	74	0.58	1.2
(HB) DB20 71 B 48	(HB) DB25 71 B 48	(HC) DC20 71 B 48	(HC) DC25 71 B 48	0.09	670	0.48	48	0.57	1.3
(HB) DB20 80 A 48	(HB) DB25 80 A 48	(HC) DC20 80 A 48	(HC) DC25 80 A 48	0.20	1360	0.71	63	0.65	1.4
(HB) DB20 80 B 48	(HB) DB25 80 B 48	(HC) DC20 80 B 48	(HC) DC25 80 B 48	0.10	660	0.67	36	0.60	1.4
(HB) DB20 90 S 48	(HB) DB25 90 S 48	(HC) DC20 90 S 48	(HC) DC25 90 S 48	0.30	1400	0.90	67	0.72	2.0
(HB) DB20 90 L 48	(HB) DB25 90 L 48	(HC) DC20 90 L 48	(HC) DC25 90 L 48	0.15	710	1.05	42	0.48	2.0
(HB) DB20 100 LA 48	(HB) DB25 100 LA 48	(HC) DC20 100 LA 48	(HC) DC25 100 LA 48	0.40	1400	1.10	63	0.83	2.7
(HB) DB20 100 LB 48	(HB) DB25 100 LB 48	(HC) DC20 100 LB 48	(HC) DC25 100 LB 48	0.20	710	1.10	47	0.56	2.7
(HB) DB20 112 M 48	(HB) DB25 112 M 48	(HC) DC20 112 M 48	(HC) DC25 112 M 48	0.60	1390	1.40	75	0.83	4.1
(HB) DB20 132 S 48	(HB) DB25 132 S 48	(HC) DC20 132 S 48	(HC) DC25 132 S 48	0.30	700	1.30	62	0.54	4.1
(HB) DB20 132 M 48	(HB) DB25 132 M 48	(HC) DC20 132 M 48	(HC) DC25 132 M 48	0.90	1370	2.00	74	0.90	6.4
(HB) DB20 132 L 48	(HB) DB25 132 L 48	(HC) DC20 132 L 48	(HC) DC25 132 L 48	0.45	710	1.70	65	0.60	6.3
(HB) DB20 160 M 48	(HB) DB25 160 M 48	(HC) DC20 160 M 48	(HC) DC25 160 M 48	1.25	1400	3.20	81	0.70	8.5
(HB) DB20 160 L 48	(HB) DB25 160 L 48	(HC) DC20 160 L 48	(HC) DC25 160 L 48	0.60	700	3.00	61	0.47	8.2
PB20 180 M 48	PB25 180 M 48	PC20 180 M 48	PC25 180 M 48	1.60	1445	3.60	73	0.88	10.6
PB20 180 L 48	PB25 180 L 48	PC20 180 L 48	PC25 180 L 48	0.80	700	4.00	59	0.49	10.9
PB20 200 LB 48	PB25 200 LB 48	PC20 200 LB 48	PC25 200 LB 48	2.55	1420	5.40	76	0.90	17.1
PB20 225 S 48	PB25 225 S 48	PC20 225 S 48	PC25 225 S 48	1.25	710	4.90	60	0.61	16.8
PB20 225 M 48	PB25 225 M 48	PC20 225 M 48	PC25 225 M 48	3.30	1430	7.20	77	0.86	22.0
				1.85	720	7.00	68	0.56	24.5
				4.80	1410	10.50	77	0.86	32.5
				2.40	700	8.10	68	0.63	32.7
				5.50	1450	11.00	87	0.83	36.2
				3.00	720	13.50	72	0.45	39.8
				7.50	1450	16.00	83	0.82	49.4
				4.80	730	15.00	83	0.56	62.8
				10.00	1440	21.00	76	0.91	66.3
				6.60	710	22.00	73	0.59	88.8
				13.00	1435	24.00	86	0.91	86.5
				8.10	710	20.50	89	0.64	108.9
				16.00	1470	31.00	85	0.88	103.9
				9.90	730	27.00	87	0.61	129.5
				20.00	1470	37.30	91	0.85	129.9
				13.00	725	39.00	86	0.56	171.2
				25.00	1460	47.50	82	0.93	163.5
				17.00	720	44.50	79	0.70	225.5
				30.00	1480	57.00	85	0.89	193.6
				20.00	730	51.00	80	0.71	261.6

DB, DC - PB, PC
Unventilated S4 40%;
Non ventilés S4 40%;
Unbelüftet S4 40%;
No ventilados S4 40%;
Non ventilati S4 40%;

HB, HC
Ventilated S1;
Ventilés S1;
Belüftet S1;
Ventilados S1;
Ventilati S1;

$$I_n^{\bullet} = I_n \cdot \frac{400}{U'}$$

(I_n = current at U' Volt);
(I_n = intensité à U' Volt);
(I_n = Strom mit U' Volt);
(I_n = corriente de U' Voltios);
(I_n = corrente a U' Volt);

Rated data at <i>Données nominales à</i> Betriebsdaten bei <i>Datos nominales</i> Dati nominali a		400 V 50 Hz	direct on line start <i>démarrage direct</i> Direkteinschaltung <i>arranque directo</i> avviamento diretto			Brake <i>Frein</i> Bremse <i>Freno</i> Freno		1500 750	rpm <i>tours/min</i> U/min <i>rev/min</i> giri/min		GB F D E I
Starting current	Starting torque		Sound pressure	Moment of inertia	Mass	Torque	Power		CESI Certificates	Class T	
<i>Intensité démarrage</i>	<i>Couple démarrage</i>		<i>Pression sonore</i>	<i>Moment d'inertie</i>	<i>Masse</i>	<i>Couple</i>	<i>Puissance</i>		<i>CESI Certificat</i>	<i>Classe T</i>	
Anlaufstrom	Anlaufmoment		Geräuschwerte	Trägheitsmoment	Masse	Moment	Leistung		CESI Konformitäts-Bescheinigung	Klasse T	
<i>Corriente de arranque</i>	<i>Par de arranque</i>		<i>Presión acústica</i>	<i>Momento de inercia</i>	<i>Peso</i>	<i>Par</i>	<i>Potencia</i>		<i>Certificados CESI</i>	<i>Clase T</i>	
Corrente avviamento	Coppia avviamento	Pressione sonora	Momento d'inerzia	Massa	Coppia	Potenza	Certificato CESI	Classe T			
I_a/I_n	M_a/M_n	Lp [dB(A)]	J ▼ [kgm ²]	m [kg]	[Nm] ●	[VA]	IIB	IIC	◆		
3.2	1.5	49	0.00112	29	9	50	03 ATEX 111	03 ATEX 110	4		
2.4	1.4										
3.4	1.6	49	0.00142	29	9	50	03 ATEX 111	03 ATEX 110	4		
2.6	1.5										
4.3	2.0	52	0.00300	36	17	60	03 ATEX 111	03 ATEX 110	4		
2.7	1.7										
3.5	1.5	52	0.00350	36	17	60	03 ATEX 111	03 ATEX 110	4		
2.5	1.3										
3.6	1.6	58	0.00450	52	35	140	03 ATEX 111	03 ATEX 110	4		
2.7	1.5										
4.0	1.8	58	0.00600	52	35	140	03 ATEX 111	03 ATEX 110	4		
3.1	1.6										
4.3	2.0	61	0.01012	62	48	180	03 ATEX 111	03 ATEX 110	4		
3.4	1.8										
4.8	1.9	61	0.01012	62	48	180	03 ATEX 111	03 ATEX 110	4		
3.7	1.6										
5.1	2.0	64	0.01939	100	70	250	03 ATEX 113	03 ATEX 112	4		
4.4	1.8										
5.0	1.7	68	0.04046	134	90	400	03 ATEX 113	03 ATEX 112	4		
4.2	1.6										
5.3	1.8	68	0.05876	134	90	400	03 ATEX 113	03 ATEX 112	4		
4.4	1.7										
5.6	1.8	68	0.05876	134	90	400	03 ATEX 113	03 ATEX 112	4		
4.6	1.8										
5.8	1.9	70	0.09691	217	130	480	03 ATEX 113	03 ATEX 112	4		
4.8	1.7										
6.9	1.8	70	0.12681	217	130	480	03 ATEX 113	03 ATEX 112	4		
5.7	1.8										
6.6	2.0	71	0.25870	280	250	670	02 ATEX 032	02 ATEX 033	4		
5.3	2.0										
6.5	1.9	71	0.25870	280	250	670	02 ATEX 032	02 ATEX 033	4		
5.3	1.9										
7.4	2.8	73	0.29560	355	320	670	02 ATEX 032	02 ATEX 033	4		
4.6	2.9										
6.5	2.1	74	0.42820	400	320	670	02 ATEX 032	02 ATEX 033	4		
5.2	1.9										
6.6	2.2	74	0.49710	450	320	670	02 ATEX 032	02 ATEX 033	4		
5.5	2.1										

$$J = \frac{PD^2}{4}$$

● For motors duty type S1 torque value to be reduced of 50%
Pour moteurs en service S1 réduire la couple donnée du 50%
 Pour moteurs en service S1 réduire la couple donnée du 50%
 Para los motores en régimen S1 el dato de par es reducido del 50%
 Per i motori con servizio S1 il valore di coppia è ridotto del 50%

◆ T3, T5 see table 1B;
T3, T5 voir tableau 1B;
 T3, T5 siehe Tabelle 1B;
T3, T5 véase tabla 1B;
 T3, T5 vedi tabella 1B;

GB	Three-phase motors	II 2G II 2GD	Speed, for hoist applications	Duty type	S4 40%
F	Moteurs triphasés		Vitesse, pour levage	Service type	
D	Drehstrom Motoren		Drehzahl, Hubmotoren	Betrieb	
E	Motores trifásicos		Velocidad, para elevación	Régimen	
I	Motori trifase		Velocità, per sollevamento	Servizio tipo	

Motor type	Rated output	Speed	Current	Efficiency	Power factor	Torque
Moteur type	Puissance	Vitesse	Intensité	Rendement	Facteur de puissance	Couple
Motor Typ	Leistung	Drehzahl	Strom	Wirkungsgrad	Leistungs-faktor	Moment
Tipo de motor	Potencia proporcionada	Velocidad	Corriente	Rendimiento	Factor de potencia	Par
Tipo motore	Potenza resa	Velocità	Corrente	Rendimento	Fattore potenza	Coppia

IIB		IIC		P _n [kW]	n [1/min]	I _n ^D [A]	η [%]	cos φ	M _n [Nm]
EEx-d	EEx-de	EEx-d	EEx-de						
(HB) DB50 71 A 6	(HB) DB55 71 A 6	(HC) DC50 71 A 6	(HC) DC55 71 A 6	0.18	930	1.10	51	0.58	1.80
(HB) DB50 71 B 6	(HB) DB55 71 B 6	(HC) DC50 71 B 6	(HC) DC55 71 B 6	0.26	925	1.20	56	0.58	2.80
(HB) DB50 80 A 6	(HB) DB55 80 A 6	(HC) DC50 80 A 6	(HC) DC55 80 A 6	0.37	930	1.60	57	0.58	3.80
(HB) DB50 80 B 6	(HB) DB55 80 B 6	(HC) DC50 80 B 6	(HC) DC55 80 B 6	0.55	930	1.80	70	0.65	5.60
(HB) DB50 90 S 6	(HB) DB55 90 S 6	(HC) DC50 90 S 6	(HC) DC55 90 S 6	0.75	950	2.40	73	0.62	7.52
(HB) DB50 90 L 6	(HB) DB55 90 L 6	(HC) DC50 90 L 6	(HC) DC55 90 L 6	1.10	955	3.78	72	0.58	11.07
(HB) DB50 100 LB 6	(HB) DB55 100 LB 6	(HC) DC50 100 LB 6	(HC) DC55 100 LB 6	1.50	960	5.00	76	0.58	15.10
(HB) DB50 112 M 6	(HB) DB55 112 M 6	(HC) DC50 112 M 6	(HC) DC55 112 M 6	2.20	972	6.95	81	0.58	22.22
(HB) DB50 132 SB 6	(HB) DB55 132 SB 6	(HC) DC50 132 SB 6	(HC) DC55 132 SB 6	3.00	975	8.70	82	0.61	29.40
(HB) DB50 132 MB 6	(HB) DB55 132 MB 6	(HC) DC50 132 MB 6	(HC) DC55 132 MB 6	4.00	970	9.20	86	0.74	39.40
(HB) DB50 132 ML 6	(HB) DB55 132 ML 6	(HC) DC50 132 ML 6	(HC) DC55 132 ML 6	5.50	960	15.5	74	0.74	54.90
(HB) DB50 160 MB 6	(HB) DB55 160 MB 6	(HC) DC50 160 MB 6	(HC) DC55 160 MB 6	7.50	976	16.80	88	0.74	73.80
(HB) DB50 160 L 6	(HB) DB55 160 L 6	(HC) DC50 160 L 6	(HC) DC55 160 L 6	11.00	968	25.60	89	0.70	109.20
PB50 180 L 6	PB55 180 L 6	PC50 180 L 6	PC55 180 L 6	15.00	984	33.41	93	0.70	145.70
PB50 200 LA 6	PB55 200 LA 6	PC50 200 LA 6	PC55 200 LA 6	18.50	○	○	○	○	○
PB50 200 LB 6	PB55 200 LB 6	PC50 200 LB 6	PC55 200 LB 6	22.00	○	○	○	○	○
PB50 225 M 6	PB55 225 M 6	PC50 225 M 6	PC55 225 M 6	30.00	○	○	○	○	○

DB, DC - PB, PC
 Unventilated;
 Non ventilés;
 Unbelüftet;
 No ventilados;
 Non ventilati;

HB, HC
 Ventilated;
 Ventilés;
 Belüftet;
 Ventilados;
 Ventilati;

○
 Data not indicated is supplied on request
 Les données qui ne sont pas indiquées sont fournies sur demande
 Die nicht angegebenen Daten werden auf Anfrage geliefert
 Los datos que no se han precisado se pueden comunicar cuando se solicite
 I dati non indicati sono forniti su richiesta

^D
 $I'_n = I_n \cdot \frac{400}{U'}$
 (I'_n = current at U' Volt);
 (I'_n = intensité à U' Volt);
 (I'_n = Strom mit U' Volt);
 (I'_n = corriente de U' Voltios);
 (I'_n = corrente a U' Volt);

Rated data at <i>Données nominales à</i> Betriebsdaten bei <i>Datos nominales</i> Dati nominali a			direct on line start <i>démarrage direct</i> Direkteinschaltung <i>arranque directo</i> avviamento diretto			Brake <i>Frein</i> Bremse <i>Freno</i> Freno		rpm <i>tours/min</i> U/min <i>rev/min</i> giri/min		GB F D E I
400 V 50 Hz								1000		
Starting current	Starting torque	Maximum torque	Sound pressure	Moment of inertia	Mass	Torque	Power	CESI Certificates	Class T	
<i>Intensité démarrage</i>	<i>Couple démarrage</i>	<i>Couple maximal</i>	<i>Pression sonore</i>	<i>Moment d'inertie</i>	<i>Masse</i>	<i>Couple</i>	<i>Puissance</i>	<i>CESI Certificat</i>	<i>Classe T</i>	
Anlaufstrom	Anlaufmoment	Kippmoment	Geräuschwerte	Trägheitsmoment	Masse	Moment	Leistung	CESI Konformitäts-Bescheinigung	Klasse T	
<i>Corriente de arranque</i>	<i>Par de arranque</i>	<i>Par máximo</i>	<i>Presión acústica</i>	<i>Momento de inercia</i>	<i>Peso</i>	<i>Par</i>	<i>Potencia</i>	<i>Certificados CESI</i>	<i>Clase T</i>	
Corrente avviamento	Coppia avviamento	Coppia massima	Pressione sonora	Momento d'inertzia	Massa	Coppia	Potenza	Certificato CESI	Classe T	
I_a/I_n	M_a/M_n	M_m/M_n	Lp [dB(A)]	J ▼ [kgm ²]	m [kg]	[Nm] ●	[VA]	IIB	IIC	◆
2.2 2.3	2.0 2.0	1.8 1.8	48 48	0.00112 0.00142	29 29	9 9	50 50	03 ATEX 111 03 ATEX 111	03 ATEX 110 03 ATEX 110	4 4
3.1 2.8	2.9 2.0	3.2 2.1	49 49	0.00300 0.00350	36 36	17 17	60 60	03 ATEX 111 03 ATEX 111	03 ATEX 110 03 ATEX 110	4 4
4.0 4.4	3.0 2.8	3.3 3.1	53 53	0.00450 0.00600	52 52	35 35	140 140	03 ATEX 111 03 ATEX 111	03 ATEX 110 03 ATEX 110	4 4
4.8	3.3	3.6	5.5	0.01012	62	48	180	03 ATEX 111	03 ATEX 110	4
5.9	2.4	2.6	57	0.01939	100	70	250	03 ATEX 113	03 ATEX 112	4
6.9 6.6 5.5	3.2 2.4 2.7	3.5 2.6 3.0	60 60 60	0.04046 0.04766 0.05876	134 134 134	90 90 90	400 400 400	03 ATEX 113 03 ATEX 113 03 ATEX 113	03 ATEX 112 03 ATEX 112 03 ATEX 112	4 4 4
6.1 6.2	2.6 2.5	2.9 2.7	64 64	0.09691 0.12681	217 217	130 130	480 480	03 ATEX 113 03 ATEX 113	03 ATEX 112 03 ATEX 112	4 4
7.6	3.0	3.3	67	0.25870	280	250	670	02 ATEX 032	02 ATEX 033	4
○ ○	○ ○	○ ○	○ ○	0.35060 0.40230	355 355	320 320	670 670	02 ATEX 032 02 ATEX 032	02 ATEX 033 02 ATEX 033	4 4
○	○	○	○	0.74850	450	320	670	02 ATEX 032	02 ATEX 033	4

$$J = \frac{PD^2}{4}$$

● For motors duty type S1 torque value to be reduced of 50%
Pour moteurs en service S1 réduire la couple donnée du 50%
für Motoren in Betrieb S1 Moment Werte Wird beim 50% reduziert
Para los motores en régimen S1 el dato de par es reducido del 50%
Per i motori con servizio S1 il valore di coppia è ridotto del 50%

◆ T3, T5 see table 1B;
T3, T5 voir tableau 1B;
T3, T5 siehe Tabelle 1B;
T3, T5 véase tabla 1B;
T3, T5 vedi tabella 1B;

GB	Three-phase motors	4.	II 2G	2	Speeds, for hoist applications	Duty type	S4
F	Moteurs triphasés				Vitesses, pour levage	Service type	
D	Drehstrom Motoren				Drehzahlen, Hubmotoren	Betrieb	
E	Motores trifásicos				Velocidades, para elevación	Régimen	
I	Motori trifase				Velocità, per sollevamento	Servizio tipo	

Motor type	Rated output	Speed	Current	Efficiency	Power factor	Torque
Moteur type	Puissance	Vitesse	Intensité	Rendement	Facteur de puissance	Couple
Motor Typ	Leistung	Drehzahl	Strom	Wirkungsgrad	Leistungs-faktor	Moment
Tipo de motor	Potencia proporcionada	Velocidad	Corriente	Rendimiento	Factor de potencia	Par
Tipo motore	Potenza resa	Velocità	Corrente	Rendimento	Fattore potenza	Coppia

IIB		IIC		P _n [kW]	n [1/min]	I _n [Ⓢ] [A]	η [%]	cos φ	M _n [Nm]
EEx-d	EEx-de	EEx-d	EEx-de						
(HB) DB50 71 B 28	(HB) DB55 71 B 28	(HC) DC50 71 B 28	(HC) DC55 71 B 28	0.30 0.06	2850 670	1.50 0.57	38 21	0.75 0.68	0.99 0.81
(HB) DB50 80 A 28	(HB) DB55 80 A 28	(HC) DC50 80 A 28	(HC) DC55 80 A 28	0.40 0.10	2905 685	1.50 0.85	41 26	0.86 0.58	1.10 1.20
(HB) DB50 80 B 28	(HB) DB55 80 B 28	(HC) DC50 80 B 28	(HC) DC55 80 B 28	0.55 0.12	2895 670	1.80 1.10	55 29	0.82 0.59	1.83 1.78
(HB) DB50 90 S 28	(HB) DB55 90 S 28	(HC) DC50 90 S 28	(HC) DC55 90 S 28	0.75 0.18	2860 690	2.50 1.50	67 30	0.79 0.58	2.50 2.50
(HB) DB50 90 L 28	(HB) DB55 90 L 28	(HC) DC50 90 L 28	(HC) DC55 90 L 28	1.10 0.30	2880 680	2.50 1.45	71 38	0.89 0.65	3.65 3.50
(HB) DB50 100 LA 28	(HB) DB55 100 LA 28	(HC) DC50 100 LA 28	(HC) DC55 100 LA 28	1.30 0.33	2960 735	3.60 2.58	71 48	0.78 0.39	4.30 4.10
(HB) DB50 100 LB 28	(HB) DB55 100 LB 28	(HC) DC50 100 LB 28	(HC) DC55 100 LB 28	1.50 0.37	2930 725	4.00 3.10	70 47	0.78 0.38	4.90 4.80
(HB) DB50 112 M 28	(HB) DB55 112 M 28	(HC) DC50 112 M 28	(HC) DC55 112 M 28	2.60 0.70	2950 720	5.50 2.70	86 69	0.81 0.55	8.51 9.30
(HB) DB50 132 S 28	(HB) DB55 132 S 28	(HC) DC50 132 S 28	(HC) DC55 132 S 28	3.50 1.10	○ ○	○ ○	○ ○	○ ○	○ ○
(HB) DB50 132 M 28	(HB) DB55 132 M 28	(HC) DC50 132 M 28	(HC) DC55 132 M 28	4.50 1.30	○ ○	○ ○	○ ○	○ ○	○ ○
(HB) DB50 132 L 28	(HB) DB55 132 L 28	(HC) DC50 132 L 28	(HC) DC55 132 L 28	5.80 1.50	○ ○	○ ○	○ ○	○ ○	○ ○

DB, DC - PB, PC
 Unventilated;
 Non ventilés;
 Unbelüftet;
 No ventilados;
 Non ventilati;

HB, HC
 Ventilated;
 Ventilés;
 Belüftet;
 Ventilados;
 Ventilati;

○
 Data not indicated is supplied on request
 Les données qui ne sont pas indiquées sont fournies sur demande
 Die nicht angegebenen Daten werden auf Anfrage geliefert
 Los datos que no se han precisado se pueden comunicar cuando se solicite
 I dati non indicati sono forniti su richiesta

$I'_n = I_n \cdot \frac{400}{U'}$
 (I'_n = current at U' Volt);
 (I'_n = intensité à U' Volt);
 (I'_n = Strom mit U' Volt);
 (I'_n = corriente de U' Voltios);
 (I'_n = corrente a U' Volt);

Rated data at <i>Données nominales à</i> Betriebsdaten bei <i>Datos nominales</i> Dati nominali a		400 V 50 Hz	direct on line start <i>démarrage direct</i> Direkteinschaltung <i>arranque directo</i> avviamento diretto			Brake <i>Frein</i> Bremse <i>Freno</i> Freno		3000 750	rpm	GB
									<i>tours/min</i>	F
									U/min	D
									<i>rev/min</i>	E
									giri/min	I
Starting current	Starting torque	Sound pressure	Moment of inertia	Mass	Torque	Power	CESI Certificates		Class T	
<i>Intensité démarrage</i>	<i>Couple démarrage</i>	<i>Pression sonore</i>	<i>Moment d'inertie</i>	<i>Masse</i>	<i>Couple</i>	<i>Puissance</i>	<i>CESI Certificat</i>		<i>Classe T</i>	
Anlaufstrom	Anlaufmoment	Geräuschwerte	Trägheitsmoment	Masse	Moment	Leistung	CESI Konformitäts-Bescheinigung		Klasse T	
<i>Corriente de arranque</i>	<i>Par de arranque</i>	<i>Presión acústica</i>	<i>Momento de inercia</i>	<i>Peso</i>	<i>Par</i>	<i>Potencia</i>	<i>Certificados CESI</i>		<i>Clase T</i>	
Corrente avviamento	Coppia avviamento	Pressione sonora	Momento d'inerzia	Massa	Coppia	Potenza	Certificato CESI		Classe T	
I_a/I_n	M_a/M_n	Lp [dB(A)]	J ▼ [kgm ²]	m [kg]	[Nm] ●	[VA]	IIB	IIC	◆	
3.5 1.6	2.0 1.4	65	0.0009	29	9	50	03 ATEX 111	03 ATEX 110	4	
5.5 1.9 4.5 1.3	2.0 1.2 2.0 1.2	55 67	0.0009 0.0013	35 35	17 17	60 60	03 ATEX 111 03 ATEX 111	03 ATEX 110 03 ATEX 110	4 4	
4.9 2.7 4.7 2.5	2.1 2.0 1.8 1.5	70 70	0.0020 0.0026	50 50	35 35	140 140	03 ATEX 111 03 ATEX 111	03 ATEX 110 03 ATEX 110	4 4	
8.6 3.0 6.1 2.4	3.7 3.6 2.5 3.7	73 74	0.0043 0.0053	60 60	48 48	180 180	03 ATEX 111 03 ATEX 111	03 ATEX 110 03 ATEX 110	4 4	
8.3 3.1	2.6 2.5	74	0.0103	97	70	250	03 ATEX 113	03 ATEX 112	4	
○ ○ ○ ○ ○ ○	○ ○ ○ ○ ○ ○	○ ○ ○ ○ ○ ○	○ ○ ○ ○ ○ ○	○ ○ ○ ○ ○ ○	90 90 90	400 400 400	03 ATEX 113 03 ATEX 113 03 ATEX 113	03 ATEX 112 03 ATEX 112 03 ATEX 112	4 4 4	

$$J = \frac{PD^2}{4}$$

● For motors duty type S1 torque value to be reduced of 50%
Pour moteurs en service S1 réduire la couple donnée du 50%
für Motoren in Betrieb S1 Moment Werte Wird beim 50% reduziert
Para los motores en régimen S1 el dato de par es reducido del 50%
Per i motori con servizio S1 il valore di coppia è ridotto del 50%

◆ T3, T5 see table 1B;
T3, T5 voir tableau 1B;
T3, T5 siehe Tabelle 1B;
T3, T5 véase tabla 1B;
T3, T5 vedi tabella 1B;

GB	Three-phase motors	Speeds, for hoist applications	Duty type
F	Moteurs triphasés	Vitesses, pour levage	Service type
D	Drehstrom Motoren	Drehzahlen, Hubmotoren	Betrieb
E	Motores trifásicos	Velocidades, para elevación	Régimen
I	Motori trifase	Velocità, per sollevamento	Servizio tipo

4.
4.4

II 2G
II 2GD

2

S4
40%

Motor type	Rated output	Speed	Current	Efficiency	Power factor	Torque
Moteur type	Puissance	Vitesse	Intensité	Rendement	Facteur de puissance	Couple
Motor Typ	Leistung	Drehzahl	Strom	Wirkungsgrad	Leistungsfaktor	Moment
Tipo de motor	Potencia proporcionada	Velocidad	Corriente	Rendimiento	Factor de potencia	Par
Tipo motore	Potenza resa	Velocità	Corrente	Rendimento	Fattore potenza	Coppia

IIB		IIC		P _n [kW]	n [1/min]	I _n [■] [A]	η [%]	cos φ	M _n [Nm]
EEx-d	EEx-de	EEx-d	EEx-de						
(HB) DB50 90 S 41	(HB) DB55 90 S 41	(HC) DC50 90 S 41	(HC) DC55 90 S 41	0.55	○	○	○	○	○
(HB) DB50 90 L 41	(HB) DB55 90 L 41	(HC) DC50 90 L 41	(HC) DC55 90 L 41	0.18	○	○	○	○	○
				0.75	○	○	○	○	○
				0.25	○	○	○	○	○
(HB) DB50 100 LA 41	(HB) DB55 100 LA 41	(HC) DC50 100 LA 41	(HC) DC55 100 LA 41	1.10	○	○	○	○	○
(HB) DB50 100 LB 41	(HB) DB55 100 LB 41	(HC) DC50 100 LB 41	(HC) DC55 100 LB 41	0.37	○	○	○	○	○
				1.50	○	○	○	○	○
				0.50	○	○	○	○	○
(HB) DB50 112 M 41	(HB) DB55 112 M 41	(HC) DC50 112 M 41	(HC) DC55 112 M 41	1.80	○	○	○	○	○
				0.60	○	○	○	○	○
(HB) DB50 132 S 41	(HB) DB55 132 S 41	(HC) DC50 132 S 41	(HC) DC55 132 S 41	2.20	○	○	○	○	○
(HB) DB50 132 M 41	(HB) DB55 132 M 41	(HC) DC50 132 M 41	(HC) DC55 132 M 41	0.73	○	○	○	○	○
(HB) DB50 132 L 41	(HB) DB55 132 L 41	(HC) DC50 132 L 41	(HC) DC55 132 L 41	3.50	○	○	○	○	○
				1.17	○	○	○	○	○
				4.00	○	○	○	○	○
				1.33	○	○	○	○	○
(HB) DB50 160 M 41	(HB) DB55 160 M 41	(HC) DC50 160 M 41	(HC) DC55 160 M 41	5.50	○	○	○	○	○
(HB) DB50 160 L 41	(HB) DB55 160 L 41	(HC) DC50 160 L 41	(HC) DC55 160 L 41	1.83	○	○	○	○	○
				7.50	○	○	○	○	○
				2.50	○	○	○	○	○
PB50 180 M 41	PB55 180 M 41	PC50 180 M 41	PC55 180 M 41	9.00	○	○	○	○	○
PB50 180 L 41	PB55 180 L 41	PC50 180 L 41	PC55 180 L 41	3.00	○	○	○	○	○
				11.60	○	○	○	○	○
				3.87	○	○	○	○	○
PB50 200 LA 41	PB55 200 LA 41	PC50 200 LA 41	PC55 200 LA 41	13.00	○	○	○	○	○
PB50 200 LB 41	PB55 200 LB 41	PC50 200 LB 41	PC55 200 LB 41	4.33	○	○	○	○	○
				16.00	○	○	○	○	○
				5.33	○	○	○	○	○
PB50 225 S 41	PB55 225 S 41	PC50 225 S 41	PC55 225 S 41	18.00	○	○	○	○	○
PB50 225 M 41	PB55 225 M 41	PC50 225 M 41	PC55 225 M 41	6.00	○	○	○	○	○
				20.00	○	○	○	○	○
				6.67	○	○	○	○	○

DB, DC - PB, PC
 Unventilated;
 Non ventilés;
 Unbelüftet;
 No ventilados;
 Non ventilati;

HB, HC
 Ventilated;
 Ventilés;
 Belüftet;
 Ventilados;
 Ventilati;

○
 Data not indicated is supplied on request
 Les données qui ne sont pas indiquées sont fournies sur demande
 Die nicht angegebenen Daten werden auf Anfrage geliefert
 Los datos que no se han precisado se pueden comunicar cuando se solicite
 I dati non indicati sono forniti su richiesta

$$I'_n = I_n \cdot \frac{400}{U'}$$

(I'_n = current at U' Volt);
 (I'_n = intensité à U' Volt);
 (I'_n = Strom mit U' Volt);
 (I'_n = corriente de U' Voltios);
 (I'_n = corrente a U' Volt);

Rated data at <i>Données nominales à</i> Betriebsdaten bei <i>Datos nominales</i> Dati nominali a		400 V 50 Hz	direct on line start <i>démarrage direct</i> Direkteinschaltung <i>arranque directo</i> avviamento diretto			Brake <i>Frein</i> Bremse <i>Freno</i> Freno		1500 500	rpm	GB
									<i>tours/min</i>	F
									U/min	D
									rev/min	E
									giri/min	I
Starting current	Starting torque	Sound pressure	Moment of inertia	Mass	Torque	Power	CESI Certificates	Class T		
<i>Intensité démarrage</i>	<i>Couple démarrage</i>	<i>Pression sonore</i>	<i>Moment d'inertie</i>	<i>Masse</i>	<i>Couple</i>	<i>Puissance</i>	<i>CESI Certificat</i>	<i>Classe T</i>		
Anlaufstrom	Anlaufmoment	Geräuschwerte	Trägheitsmoment	Masse	Moment	Leistung	CESI Konformitäts-Bescheinigung	Klasse T		
<i>Corriente de arranque</i>	<i>Par de arranque</i>	<i>Presión acústica</i>	<i>Momento de inercia</i>	<i>Peso</i>	<i>Par</i>	<i>Potencia</i>	<i>Certificados CESI</i>	<i>Clase T</i>		
Corrente avviamento	Coppia avviamento	Pressione sonora	Momento d'inerzia	Massa	Coppia	Potenza	Certificato CESI	Classe T		
I_a/I_n	M_a/M_n	Lp [dB(A)]	J ▼ [kgm ²]	m [kg]	[Nm] ●	[VA]	IIB	IIC	◆	
○	○	○	○	○	35	140	03 ATEX 111	03 ATEX 110	4	
○	○	○	○	○	35	140	03 ATEX 111	03 ATEX 110	4	
○	○	○	○	○	35	140	03 ATEX 111	03 ATEX 110	4	
○	○	○	○	○	35	140	03 ATEX 111	03 ATEX 110	4	
○	○	○	○	○	48	180	03 ATEX 111	03 ATEX 110	4	
○	○	○	○	○	48	180	03 ATEX 111	03 ATEX 110	4	
○	○	○	○	○	48	180	03 ATEX 111	03 ATEX 110	4	
○	○	○	○	○	70	250	03 ATEX 113	03 ATEX 112	4	
○	○	○	○	○	70	250	03 ATEX 113	03 ATEX 112	4	
○	○	○	○	○	90	400	03 ATEX 113	03 ATEX 112	4	
○	○	○	○	○	90	400	03 ATEX 113	03 ATEX 112	4	
○	○	○	○	○	90	400	03 ATEX 113	03 ATEX 112	4	
○	○	○	○	○	90	400	03 ATEX 113	03 ATEX 112	4	
○	○	○	○	○	130	480	03 ATEX 113	03 ATEX 112	4	
○	○	○	○	○	130	480	03 ATEX 113	02 ATEX 112	4	
○	○	○	○	○	130	480	03 ATEX 113	02 ATEX 112	4	
○	○	○	○	○	130	480	03 ATEX 113	02 ATEX 112	4	
○	○	○	○	○	250	670	02 ATEX 032	02 ATEX 033	4	
○	○	○	○	○	250	670	02 ATEX 032	02 ATEX 033	4	
○	○	○	○	○	250	670	02 ATEX 032	02 ATEX 033	4	
○	○	○	○	○	250	670	02 ATEX 032	02 ATEX 033	4	
○	○	○	○	○	320	670	02 ATEX 032	02 ATEX 033	4	
○	○	○	○	○	320	670	02 ATEX 032	02 ATEX 033	4	
○	○	○	○	○	320	670	02 ATEX 032	02 ATEX 033	4	
○	○	○	○	○	320	670	02 ATEX 032	02 ATEX 033	4	
○	○	○	○	○	320	670	02 ATEX 032	02 ATEX 033	4	
○	○	○	○	○	320	670	02 ATEX 032	02 ATEX 033	4	
○	○	○	○	○	320	670	02 ATEX 032	02 ATEX 033	4	

$$J = \frac{PD^2}{4}$$

▼ For motors duty type S1 torque value to be reduced of 50%
Pour moteurs en service S1 réduire la couple donnée du 50%
für Motoren in Betrieb S1 Moment Werte Wird beim 50% reduziert
Para los motores en régimen S1 el dato de par es reducido del 50%
Per i motori con servizio S1 il valore di coppia è ridotto del 50%

◆ T3, T5 see table 1B;
T3, T5 voir tableau 1B;
T3, T5 siehe Tabelle 1B;
T3, T5 véase tabla 1B;
T3, T5 vedi tabella 1B;

GB	Three-phase motors	4. 4.4	II 2G II 2GD	2	Speeds, for hoist applications	Duty type	S4 40%
F	Moteurs triphasés				Vitesses, pour levage	Service type	
D	Drehstrom Motoren				Drehzahlen, Hubmotoren	Betrieb	
E	Motores trifásicos				Velocidades, para elevación	Régimen	
I	Motori trifase				Velocità, per sollevamento	Servizio tipo	

Motor type	Rated output	Speed	Current	Efficiency	Power factor	Torque
Moteur type	Puissance	Vitesse	Intensité	Rendement	Facteur de puissance	Couple
Motor Typ	Leistung	Drehzahl	Strom	Wirkungsgrad	Leistungsfaktor	Moment
Tipo de motor	Potencia proporcionada	Velocidad	Corriente	Rendimiento	Factor de potencia	Par
Tipo motore	Potenza resa	Velocità	Corrente	Rendimento	Fattore potenza	Coppia

IIB		IIC		P _n [kW]	n [1/min]	I _n [■] [A]	η [%]	cos φ	M _n [Nm]
EEx-d	EEx-de	EEx-d	EEx-de						
(HB) DB50 132 S 43	(HB) DB55 132 S 43	(HC) DC50 132 S 43	(HC) DC55 132 S 43	2.20	○	○	○	○	○
				0.55	○	○	○	○	○
(HB) DB50 132 M 43	(HB) DB55 132 M 43	(HC) DC50 132 M 43	(HC) DC55 132 M 43	3.50	○	○	○	○	○
				0.88	○	○	○	○	○
(HB) DB50 132 L 43	(HB) DB55 132 L 43	(HC) DC50 132 L 43	(HC) DC55 132 L 43	4.00	○	○	○	○	○
				1.00	○	○	○	○	○
(HB) DB50 160 M 43	(HB) DB55 160 M 43	(HC) DC50 160 M 43	(HC) DC55 160 M 43	5.50	○	○	○	○	○
				1.38	○	○	○	○	○
(HB) DB50 160 L 43	(HB) DB55 160 L 43	(HC) DC50 160 L 43	(HC) DC55 160 L 43	7.50	○	○	○	○	○
				1.88	○	○	○	○	○
PB50 180 M 43	PB55 180 M 43	PC50 180 M 43	PC55 180 M 43	8.00	○	○	○	○	○
				2.00	○	○	○	○	○
PB50 180 L 43	PB55 180 L 43	PC50 180 L 43	PC55 180 L 43	9.50	○	○	○	○	○
				2.38	○	○	○	○	○
PB50 200 LA 43	PB55 200 LA 43	PC50 200 LA 43	PC55 200 LA 43	11.00	○	○	○	○	○
				2.75	○	○	○	○	○
PB50 200 LB 43	PB55 200 LB 43	PC50 200 LB 43	PC55 200 LB 43	13.00	○	○	○	○	○
				3.25	○	○	○	○	○
PB50 225 S 43	PB55 225 S 43	PC50 225 S 43	PC55 225 S 43	15.00	○	○	○	○	○
				3.75	○	○	○	○	○
PB50 225 M 43	PB55 225 M 43	PC50 225 M 43	PC55 225 M 43	18.50	○	○	○	○	○
				4.63	○	○	○	○	○

DB, DC - PB, PC
 Unventilated;
 Non ventilés;
 Unbelüftet;
 No ventilados;
 Non ventilati;

HB, HC
 Ventilated;
 Ventilés;
 Belüftet;
 Ventilados;
 Ventilati;

○
 Data not indicated is supplied on request
 Les données qui ne sont pas indiquées sont fournies sur demande
 Die nicht angegebenen Daten werden auf Anfrage geliefert
 Los datos que no se han precisado se pueden comunicar cuando se solicita
 I dati non indicati sono forniti su richiesta

■
 $I'_n = I_n \cdot \frac{400}{U'}$
 (I'_n = current at U' Volt);
 (I'_n = intensité à U' Volt);
 (I'_n = Strom mit U' Volt);
 (I'_n = corriente de U' Voltios);
 (I'_n = corrente a U' Volt);

Rated data at <i>Données nominales à</i> Betriebsdaten bei <i>Datos nominales</i> Dati nominali a		400 V 50 Hz	direct on line start <i>démarrage direct</i> Direkteinschaltung <i>arranque directo</i> avviamento diretto			Brake <i>Frein</i> Bremse <i>Freno</i> Freno		1500 375	rpm	GB
									<i>tours/min</i>	F
									U/min	D
									<i>rev/min</i>	E
									giri/min	I
Starting current	Starting torque	Sound pressure	Moment of inertia	Mass	Torque	Power	CESI Certificates		Class T	
<i>Intensité démarrage</i>	<i>Couple démarrage</i>	<i>Pression sonore</i>	<i>Moment d'inertie</i>	<i>Masse</i>	<i>Couple</i>	<i>Puissance</i>	<i>CESI Certificat</i>		<i>Classe T</i>	
Anlaufstrom	Anlaufmoment	Geräuschwerte	Trägheitsmoment	Masse	Moment	Leistung	CESI Konformitäts-Bescheinigung		Klasse T	
<i>Corriente de arranque</i>	<i>Par de arranque</i>	<i>Presión acústica</i>	<i>Momento de inercia</i>	<i>Peso</i>	<i>Par</i>	<i>Potencia</i>	<i>Certificados CESI</i>		<i>Clase T</i>	
Corrente avviamento	Coppia avviamento	Pressione sonora	Momento d'inerzia	Massa	Coppia	Potenza	Certificato CESI		Classe T	
I_a/I_n	M_a/M_n	Lp [dB(A)]	J ▼ [kgm ²]	m [kg]	[Nm] ●	[VA]	IIB	IIC	◆	
○	○	○	○	○	90	400	03 ATEX 113	03 ATEX 112	4	
○	○	○	○	○	90	400	03 ATEX 113	03 ATEX 112	4	
○	○	○	○	○	90	400	03 ATEX 113	03 ATEX 112	4	
○	○	○	○	○	90	400	03 ATEX 113	03 ATEX 112	4	
○	○	○	○	○	90	400	03 ATEX 113	03 ATEX 112	4	
○	○	○	○	○	130	480	03 ATEX 113	03 ATEX 112	4	
○	○	○	○	○	130	480	03 ATEX 113	02 ATEX 112	4	
○	○	○	○	○	130	480	03 ATEX 113	02 ATEX 112	4	
○	○	○	○	○	250	670	02 ATEX 032	02 ATEX 033	4	
○	○	○	○	○	250	670	02 ATEX 032	02 ATEX 033	4	
○	○	○	○	○	250	670	02 ATEX 032	02 ATEX 033	4	
○	○	○	○	○	250	670	02 ATEX 032	02 ATEX 033	4	
○	○	○	○	○	320	670	02 ATEX 032	02 ATEX 033	4	
○	○	○	○	○	320	670	02 ATEX 032	02 ATEX 033	4	
○	○	○	○	○	320	670	02 ATEX 032	02 ATEX 033	4	
○	○	○	○	○	320	670	02 ATEX 032	02 ATEX 033	4	
○	○	○	○	○	320	670	02 ATEX 032	02 ATEX 033	4	
○	○	○	○	○	320	670	02 ATEX 032	02 ATEX 033	4	

$$J = \frac{PD^2}{4}$$

● For motors duty type S1 torque value to be reduced of 50%
Pour moteurs en service S1 réduire la couple donnée du 50%
für Motoren in Betrieb S1 Moment Werte Wird beim 50% reduziert
Para los motores en régimen S1 el dato de par es reducido del 50%
Per i motori con servizio S1 il valore di coppia è ridotto del 50%

◆ T3, T5 see table 1B;
T3, T5 voir tableau 1B;
T3, T5 siehe Tabelle 1B;
T3, T5 véase tabla 1B;
T3, T5 vedi tabella 1B;

5. Overall dimensions

- 5.1 Motors with integrated brake
- 5.2 Motors with external brake

5. *Dimensions*

- 5.1 *Moteurs à frein intégré*
- 5.2 *Moteurs à frein externe*

5. **Abmessungen**

- 5.1 Motoren mit integrierter Bremse
- 5.2 Motoren mit äußerer Bremse

5. *Dimensiones*

- 5.1 *Motores con freno integrado*
- 5.2 *Motores con freno externo*

5. **Dimensioni d'ingombro**

- 5.1 Motori con freno integrato
- 5.2 Motori con freno esterno

GB	Motors with integrated brake	DB	HB			
F	Moteurs à frein intégré	DC	HC			
D	Motoren mit integrierter Bremse					
E	Motores con freno integrado					
I	5.1 Motori con freno integrato	63÷160	71÷160	IM B3	IM B5	IM B35

IM B3

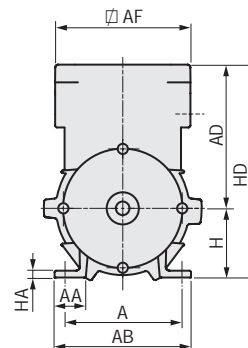
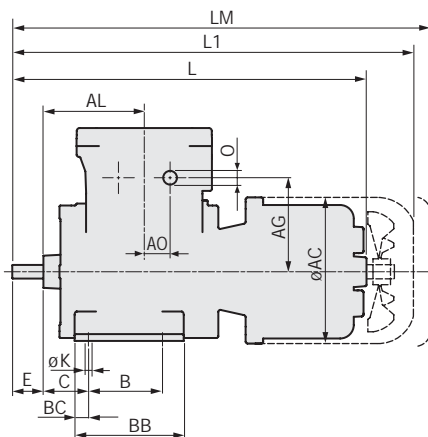

IM B5

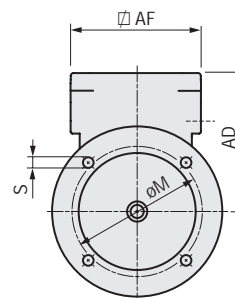
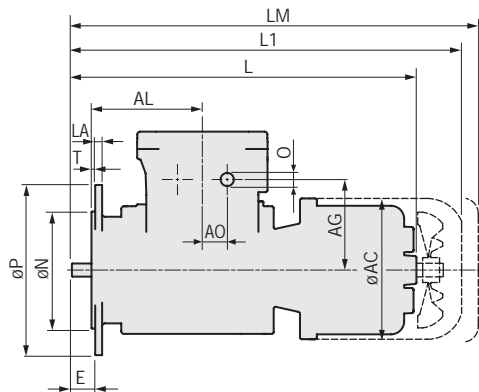

IM B35

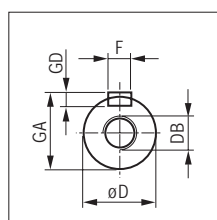
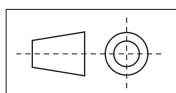
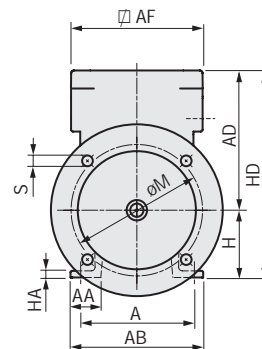
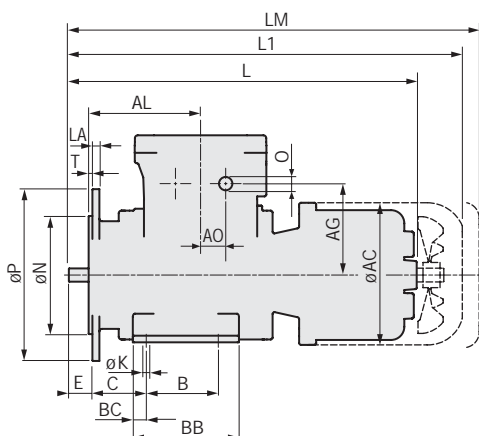

Overall dimensions [mm]

GB

Dimensions [mm]

F

Abmessungen [mm]

D

Dimensiones [mm]

E

Dimensioni d'ingombro [mm]

I

Type	IM B5 IM B3-B35																	
	A	AA	AB	∅ AC	AD	AF	AL	AL	B	BC	BB	C	H _{0.5}	HA	HD	∅ K	L	L1
63	100	25	125	134	174	145	93	93	80	12	105	40	63	6	237	7	310	
71	112	32	140	167	184	145	106	106	90	11	112	45	71	7	255	7	370	415
80	125	37	160	180	195	145	142	142	100	15	130	50	80	8	275	9	425	470
90 S	140	45	175	210	204	145	124	124	100	12	157	56	90	9	294	9	505	550
90 L	140	45	175	210	204	145	124	124	125	12	157	56	90	9	294	9	505	550
100	160	45	200	232	215	145	125	125	140	15	170	63	100	10	315	12	540	590
112	190	45	235	258	231	205	200	165	140	17	175	70	112	12	343	12	610	670
132 S	216	56	272	311	258	205	193	163	140	22	222	89	132	13	390	12	650	720
132 ML	216	56	272	311	258	205	268	163	178	22	222	89	132	13	390	12	725	795
160 M	254	64	318	346	285	205	310	165	210	25	305	108	160	15	445	14	825	895
160 L	254	64	318	346	285	205	310	165	254	25	305	108	160	15	445	14	825	895

Type	IEC 423																
	* ▼ LM	AO	n. x O	AG	∅ D	E	F	GA	GD	DB	LA	∅ M	∅ N	∅ P	S	T	
63		25	1xM25 1xM20	96	11j6	23	4	12.5	4	M4	8	115	95j6	140	10	3	
71	442	25	1xM25 1xM20	105	14j6	30	5	16	5	M5	10	130	110j6	160	10	3.5	
80	495	25	1xM25 1xM20	116	19j6	40	6	21.5	6	M6	11	165	130j6	200	12	3.5	
90 S	575	25	1xM25 1xM20	125	24j6	50	8	27	7	M8	11	165	130j6	200	12	3.5	
90 L	575	25	1xM25 1xM20	125	24j6	50	8	27	7	M8	11	165	130j6	200	12	3.5	
100	620	25	1xM25 1xM20	135	28j6	60	8	31	7	M10	14	215	180j6	250	15	4	
112	710	35	2xM32 1xM20	147	28j6	60	8	31	7	M10	16	215	180j6	250	15	4	
132 S	770	35	2xM32 1xM20	164	38k6	80	10	41	8	M12	17	265	230j6	300	15	4	
132 ML	845	35	2xM32 1xM20	164	38k6	80	10	41	8	M12	17	265	230j6	300	15	4	
160 M	940	35	2xM32 1xM20	207	42k6	110	12	45	8	M16	18	300	250h6	350	18	5	
160 L	940	35	2xM32 1xM20	207	42k6	110	12	45	8	M16	18	300	250h6	350	18	5	

●
Version DB, DC
Version DB, DC
Ausführung DB, DC
Versión DB, DC
Versione DB, DC

▼
Version HB, HC
Version HB, HC
Ausführung HB, HC
Versión HB, HC
Versione HB, HC

⏚ 1 in the terminal box, 1 on the frame
1 à l'intérieur de la boîte à bornes, 1 sur la carcasse
1 am Klemmkasten, 1 am Motorgehäuse
1 en la caja de bornes, 1 en la carcasa
1 nella scatola morsetti, 1 sulla carcassa

Tolerances allowed
Dimensions données à titre indicatif
Übliche Toleranzen
Cotas no vinculantes
Quote non impegnative

*
rain cover: normally found only on self-ventilating motors (IC411) for vertical assembly, shaft at the bottom
capot parapluie: normalement, elle n'est présente que sur les moteurs autoventilés (IC411) destinés à un montage vertical, arbre en bas
Regenschutz: ist normalerweise nur bei den eigenbelüfteten Motoren (IC411) für die senkrechte Montage, Welle unten, vorhanden
tapa de protección contra la lluvia: normalmente sólo está presente en los motores autoventilados (IC411) para el montaje en vertical, con el eje en la parte inferior
parapioggia: normalmente presente solo nei motori autoventilati (IC411) per montaggio verticale, albero in basso

GB	Motors with integrated brake	DB	HB		
F	Moteurs à frein intégré	DC	HC		
D	Motoren mit integrierter Bremse				
E	Motores con freno integrado	63÷160	71÷160	IM B14	IM B34
I	5.1 Motori con freno integrato				

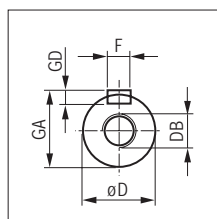
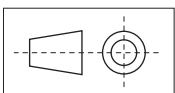
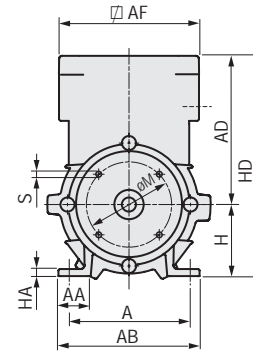
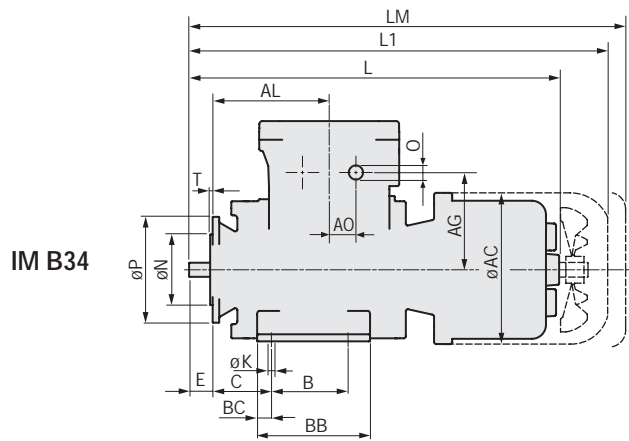
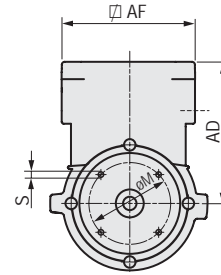
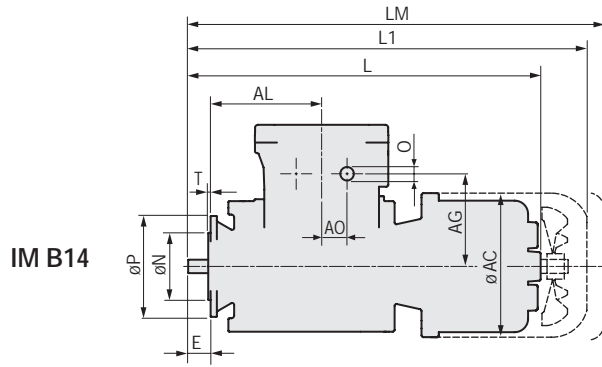

Overall dimensions [mm]

GB

Dimensions [mm]

F

Abmessungen [mm]

D

Dimensiones [mm]

E

Dimensioni d'ingombro [mm]

I

Type	IM B14 IM B34																●	▼
	A	AA	AB	∅ AC	AD	∅ AF	AL	AL	B	BC	BB	C	H. ∅ ₅	HA	HD	∅ K	L	L1
63	100	25	125	134	174	145	93	93	80	12	105	40	63	6	237	7	310	
71	112	32	140	167	184	145	106	106	90	11	112	45	71	7	255	7	370	415
80	125	37	160	180	195	145	142	142	100	15	130	50	80	8	275	9	425	470
90 S	140	45	175	210	204	145	124	124	100	12	157	56	90	9	294	9	505	550
90 L	140	45	175	210	204	145	124	124	125	12	157	56	90	9	294	9	505	550
100	160	45	200	232	215	145	125	125	140	15	170	63	100	10	315	12	540	590
112	190	45	235	258	231	205	200	165	140	17	175	70	112	12	343	12	610	670
132 S	216	56	272	311	258	205	193	163	140	22	222	89	132	13	380	12	650	720
132 ML	216	56	272	311	258	205	268	163	178	22	222	89	132	13	390	12	725	795
160 M	254	64	318	346	285	205	310	165	210	25	305	108	160	15	445	14	825	895
160 L	254	64	318	346	285	205	310	165	254	25	305	108	160	15	445	14	825	895

Type	* ▼	IEC 423														S	T
	LM	AO	n. x O	AG	∅ D	E	F	GA	GD	DB	∅ M	∅ N	∅ P				
63		25	1xM25 1xM20	96	11j6	23	4	12.5	4	M4	75	60j6	90	M5	2.5		
71	442	25	1xM25 1xM20	105	14j6	30	5	16	5	M5	85	70j6	105	M6	2.5		
80	495	25	1xM25 1xM20	116	19j6	40	6	21.5	6	M6	100	80j6	120	M6	3		
90 S	575	25	1xM25 1xM20	125	24j6	50	8	27	7	M8	115	95j6	140	M8	3		
90 L	575	25	1xM25 1xM20	125	24j6	50	8	27	7	M8	115	95j6	140	M8	3		
100	620	25	1xM25 1xM20	135	28j6	60	8	31	7	M10	130	110j6	160	M8	3.5		
112	710	35	2xM32 1xM20	147	28j6	60	8	31	7	M10	130	110j6	160	M8	3.5		
132 S	770	35	2xM32 1xM20	164	38k6	80	10	41	8	M12	165	130j6	200	M10	3.5		
132 ML	845	35	2xM32 1xM20	164	38k6	80	10	41	8	M12	165	130j6	200	M10	3.5		
160 M	940	35	2xM32 1xM20	207	42k6	110	12	45	8	M16	215	180h6	250	M12	4		
160 L	940	35	2xM32 1xM20	207	42k6	110	12	45	8	M16	215	180h6	250	M12	4		

●
Version DB, DC
Version DB, DC
Ausführung DB, DC
Versión DB, DC
Versione DB, DC

▼
Version HB, HC
Version HB, HC
Ausführung HB, HC
Versión HB, HC
Versione HB, HC

⏚ 1 in the terminal box, 1 on the frame
1 à l'intérieur de la boîte à bornes, 1 sur la carcasse
1 am Klemmkasten, 1 am Motorgehäuse
1 en la caja de bornes, 1 en la carcasa
1 nella scatola morsetti, 1 sulla carcassa

Tolerances allowed
Dimensions données à titre indicatif
Übliche Toleranzen
Cotas no vinculantes
Quote non impegnative

*
rain cover: normally found only on self-ventilating motors (IC411) for vertical assembly, shaft at the bottom
capot parapluie: normalement, elle n'est présente que sur les moteurs autoventilés (IC411) destinés à un montage vertical, arbre en bas
Regenschutz: ist normalerweise nur bei den eigenbelüfteten Motoren (IC411) für die senkrechte Montage, Welle unten, vorhanden
tapa de protección contra la lluvia: normalmente sólo está presente en los motores autoventilados (IC411) para el montaje en vertical, con el eje en la parte inferior
parapioggia: normalmente presente solo nei motori autoventilati (IC411) per montaggio verticale, albero in basso

IM B3

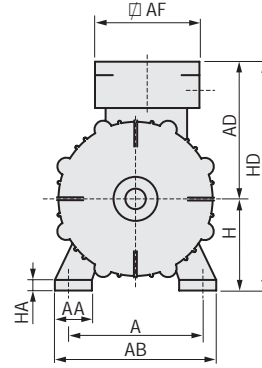
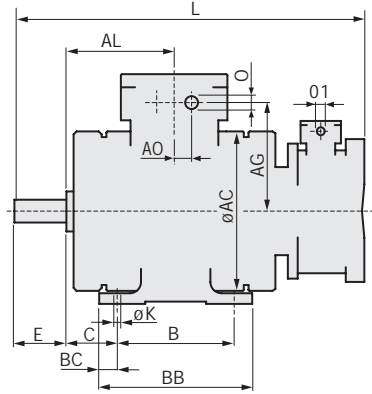

IM B5

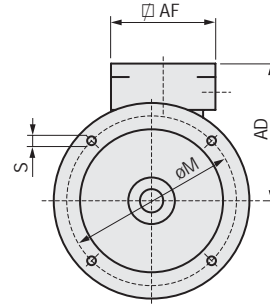
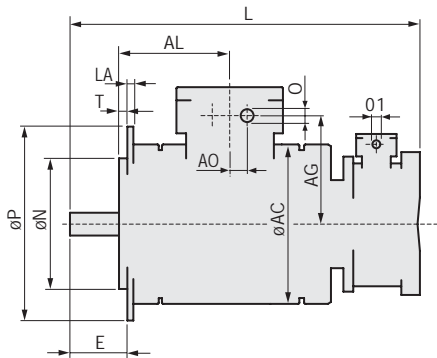

IM B35

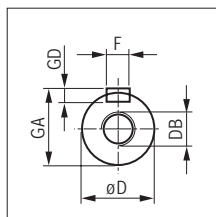
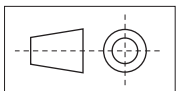
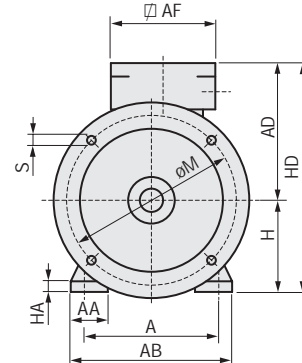
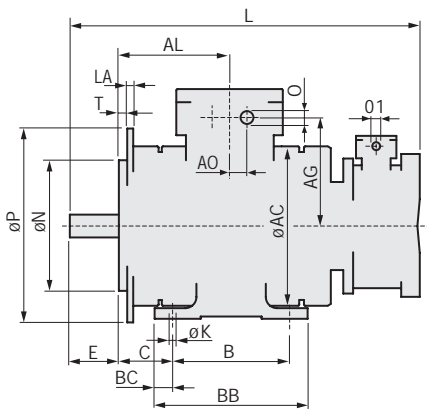

180-225

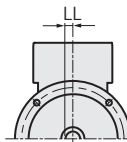

225

- ◆ 8 holes
- 8 trous
- 8 Bohrungen
- 8 orificios
- 8 fori

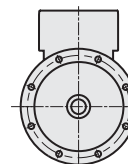

Overall dimensions [mm]

GB

Dimensions [mm]

F

Abmessungen [mm]

D

Dimensiones [mm]

E

Dimensioni d'ingombro [mm]

I

Type	A	AA	AB	∅ AC	AD	∇ AF	AL	B	BC	BB	C	H _{-0,5}	HA	HD	∅ K	L	LL
180 M	279	71	350	360	326	228	212	241	25	329	121	180	25	506	14	861	49
180 L	279	71	360	359	326	228	212	279	25	329	121	180	25	506	14	750	49
200	318	75	395	395	341	228	232	305	32	360	133	200	28	541	18	910	43
225 S	356	75	445	445	363	228	244	286	35	380	149	225	30	588	18	943	38
225 M 4-8	356	75	431	445	363	228	244	311	35	380	149	225	30	588	18	880	38

Type	IEC 423		AG	∅ D	E	F	GA	GD	DB	LA	∅ M	∅ N	∅ P	S	T
	AO	n. x O n. x 01													
180 M	40	2xM40 1xM20	265	48k6	110	14	51.5	9	M16	20	300	250h6	350	18	5
180 L	40	2xM40 1xM20	265	48k6	110	14	51.5	9	M16	20	300	250h6	350	18	5
200	40	2xM40 1xM20	281	55m6	110	16	59	10	M20	20	350	300h6	400	18	5
225 S	40	2xM40 1xM20	302	60m6	140	18	64	11	M20	22	400	350h6	450	18♦	5
225 M 4-8	40	2xM40 1xM20	302	65m6	140	18	64	11	M20	22	400	350h6	450	18♦	5

♦
see page 94;
voir page 94;
siehe Seite 94;
véase página 94;
vedi pagina 94;

⏏ 1 in the terminal box, 1 on the frame
1 à l'intérieur de la boîte à bornes, 1 sur la carcasse
1 am Klemmkasten, 1 am Motorgehäuse
1 en la caja de bornes, 1 en la carcasa
1 nella scatola morsetti, 1 sulla carcassa

Tolerances allowed
Dimensions données à titre indicatif
Übliche Toleranzen
Cotas no vinculantes
Quote non impegnative

6. Spare parts

6.1 Motors with integrated brake

6.2 Motors with external brake

6. Pièces détachées

6.1 *Moteurs à frein intégré*

6.2 *Moteurs à frein externe*

6. Ersatzteilliste

6.1 Motoren mit integrierter Bremse

6.2 Motoren mit äußerer Bremse

6. Piezas de repuesto

6.1 *Motores con freno integrado*

6.2 *Motores con freno externo*

6. Parti di ricambio

6.1 Motori con freno integrato

6.2 Motori con freno esterno

GB
F
D
E
I

Motors with integrated brake
Moteurs à frein intégré
Motoren mit integrierter Bremse
Motores con freno integrado
Motori con freno integrato

DB
DC
63÷160

6.
6.1

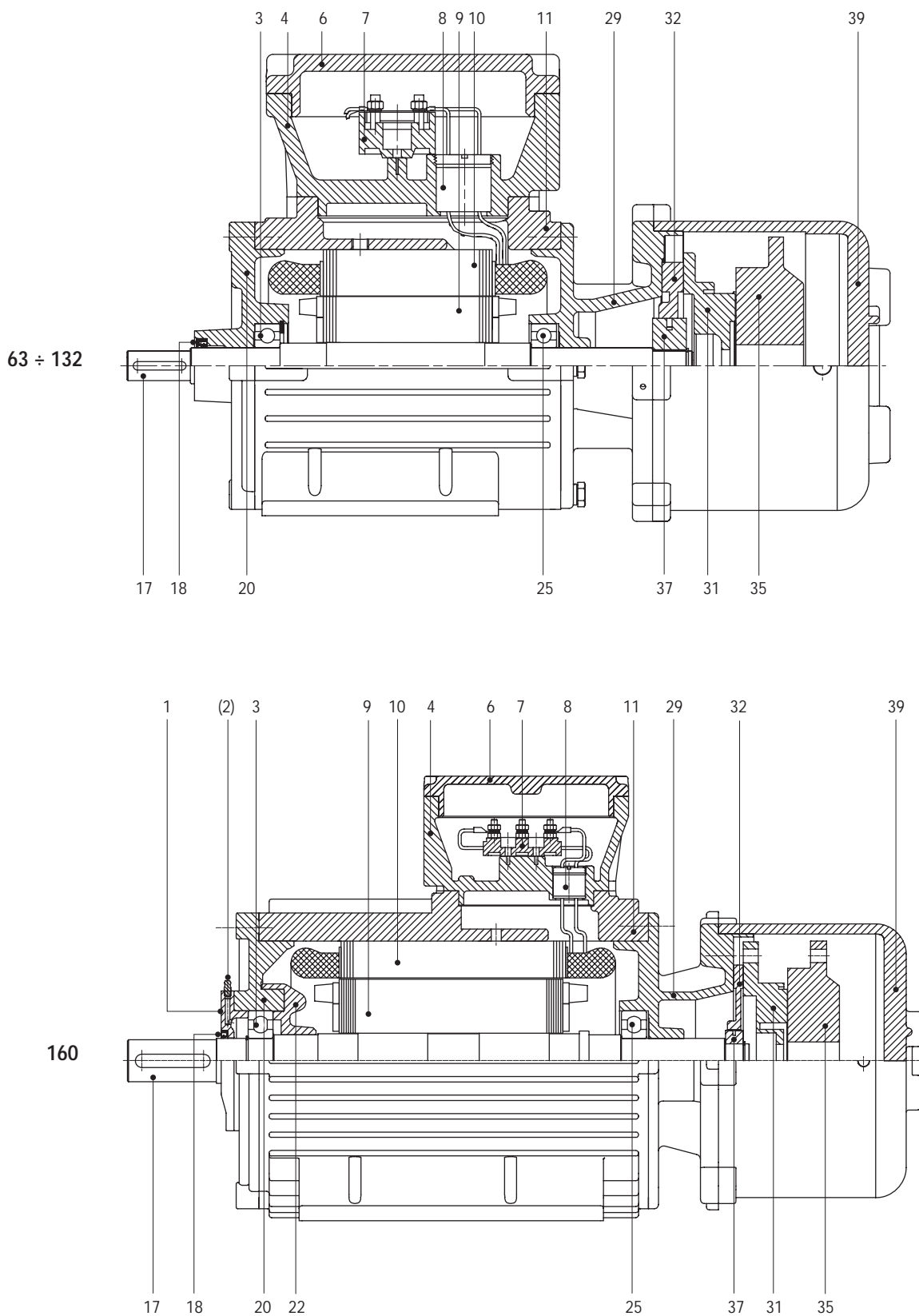

GB

1 End cap - front	10 Stator	31 Mobil armature
(2) Grease nipple - front	11 Frame	32 Braking disks
3 Front bearing	17 Shaft	35 Magnet
4 Terminal box	18 Sealing ring - front	37 Gear
6 Terminal box lid	20 Endshield - front	39 Brake cover enclosure
7 Terminal board	22 Inner bearing cap - front	
8 Cable nipple	25 Rear bearing	
9 Rotor	29 Brake holder back shield	

(...) = when provided

F

1 Couvercle avant	10 Stator	31 Armature
(2) Graisseur avant	11 Carcasse	32 Disques de freinage
3 Roulement avant	17 Arbre	35 Aimant
4 Boîte à bornes	18 Bague avant d'étanchéité	37 Engrenage
6 Couvercle boîte à bornes	20 Flasque avant	39 Carter de protection du frein
7 Bornes	22 Flasque intérieur avant	
8 Dispositif pour le passage des câbles	25 Roulement arrière	
9 Rotor	29 Flasque arrière porte-frein	

(...) = si c'est prévu

D

1 Äußerer Fettkammerdeckel A-Seite	10 Statorpaket	31 Anker
(2) Schmiernippel A-Seite	11 Motorgehäuse	32 Bremsscheiben
3 Kugellager A-Seite	17 Welle	35 Magnet
4 Klemmkasten	18 Dichtungsring A-Seite	37 Zahnrad
6 Klemmkastendeckel	20 Lagerschild A-Seite	39 Kapselung Bremsabdeckung
7 Klemmbrett	22 Innerer Fettkammerdeckel A-Seite	
8 Druckfeste Kabeldurchführung	25 Kugellager B-Seite	
9 Läufer	29 Lagerschild B-Seite Bremsenhalter	

(...) = wenn vorgesehen

E

1 Tapa externa delantera	10 Estator	31 Placa móvil
(2) Engrasador delantero	11 Armazón	32 Discos de freno
3 Cojinete delantero	17 Eje	35 Imán
4 Caja de bornes	18 Anillo de retención delantero	37 Piñón dentado
6 Tapa de la caja de bornes	20 Escudo delantero	39 Protector del freno
7 Placa de bornes	22 Fondo interno delantero	
8 Niple paso cables	25 Cojinete trasero	
9 Rotor	29 Escudo posterior portafrenos	

(...) = cuando previsto

I

1 Fondello esterno anteriore	10 Statore	31 Ancora mobile
(2) Ingrassatore anteriore	11 Carcassa	32 Dischi frenanti
3 Cuscinetto anteriore	17 Albero	35 Magnete
4 Scatola morsetti	18 Anello di tenuta anteriore	37 Ingranaggio
6 Coperchio scatola morsetti	20 Scudo anteriore	39 Custodia coprifreno
7 Morsettiera	22 Fondello interno anteriore	
8 Nipplo passaggio cavi	25 Cuscinetto posteriore	
9 Rotore	29 Scudo posteriore portafreno	

(...) = quando previsto

GB
F
D
E
I

Motors with integrated brake
Moteurs à frein intégré
Motoren mit integrierter Bremse
Motores con freno integrado
Motori con freno integrato

HB
HC
71÷160

6.
6.1

71 ÷ 132

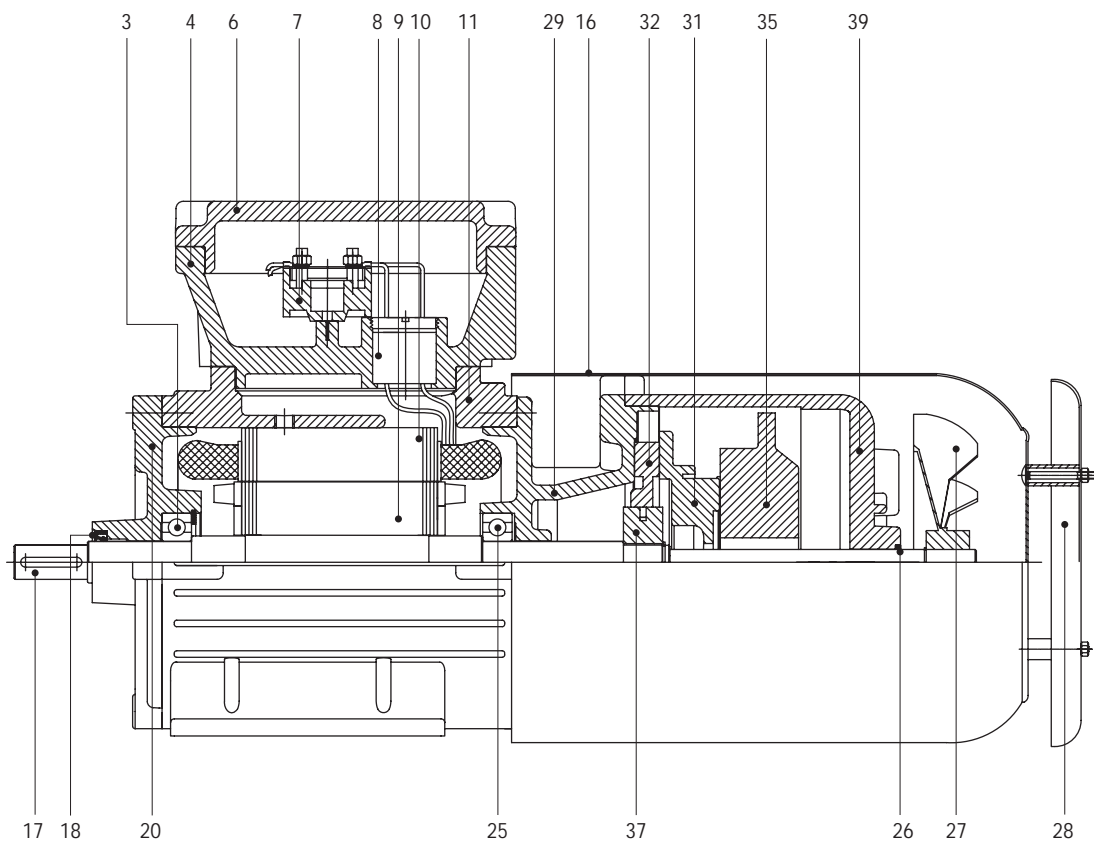

160

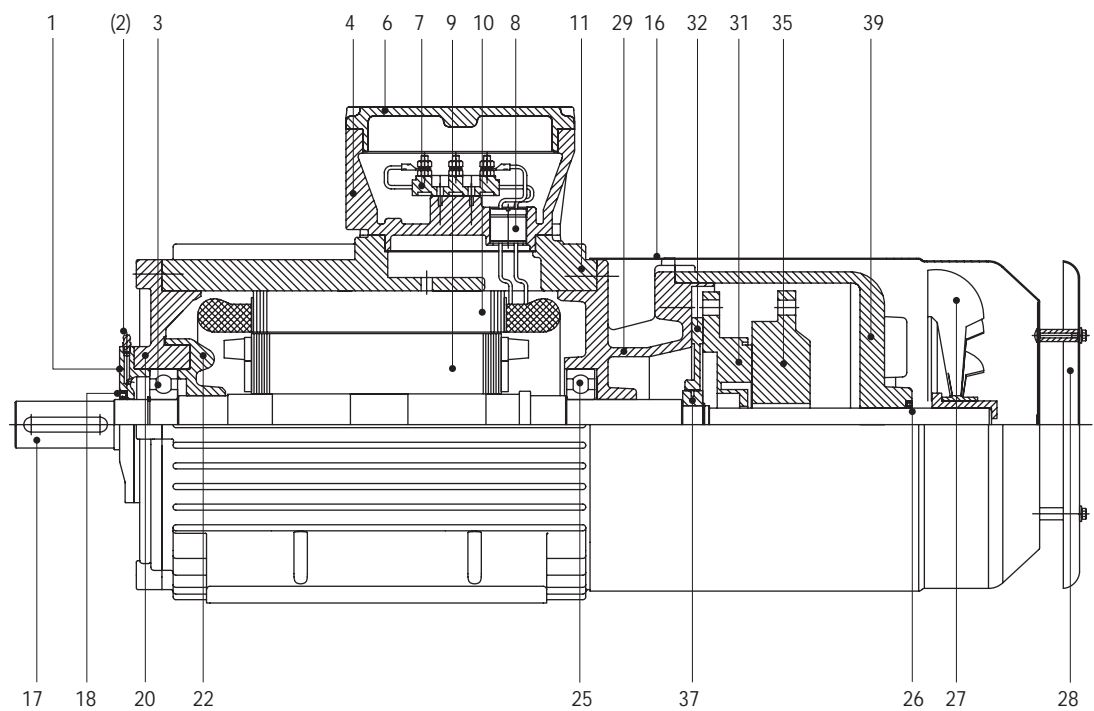

GB

1 End cap - front	11 Frame	(28) Rain cap
(2) Grease nipple - front	16 Fan cover (cowl)	29 Brake holder back shield
3 Front bearing	17 Shaft	31 Mobil armature
4 Terminal box	18 Sealing ring - front	32 Braking disks
6 Terminal box lid	20 Endshield - front	35 Magnet
7 Terminal board	22 Inner bearing cap - front	37 Gear
8 Cable nipple	25 Rear bearing	39 Brake cover enclosure
9 Rotor	26 Sealing ring - rear	
10 Stator	27 Cooling fan	

(...) = when provided

F

1 Couvercle avant	11 Carcasse	(28) Tôle parapluie
(2) Graisseur avant	16 Capot de ventilateur	29 Flasque arrière porte-frein
3 Roulement avant	17 Arbre	31 Armature
4 Boîte à bornes	18 Bague avant d'étanchéité	32 Disques de freinage
6 Couvercle boîte à bornes	20 Flasque avant	35 Aimant
7 Bornes	22 Flasque intérieur avant	37 Engrenage
8 Dispositif pour le passage des câbles	25 Roulement arrière	39 Carter de protection du frein
9 Rotor	26 Bague arrière d'étanchéité	
10 Stator	27 Ventilateur	

(...) = si c'est prévu

D

1 Äußerer Fettkammerdeckel A-Seite	11 Motorgehäuse	(28) Regenschutzdach
(2) Schmiernippel A-Seite	16 Lüfterhaube	29 Lagerschild B-Seite Bremsenhalter
3 Kugellager A-Seite	17 Welle	31 Anker
4 Klemmkasten	18 Dichtungsring A-Seite	32 Bremsscheiben
6 Klemmkastendeckel	20 Lagerschild A-Seite	35 Magnet
7 Klemmbrett	22 Innerer Fettkammerdeckel A-Seite	37 Zahnrad
8 Druckfeste Kabeldurchführung	25 Kugellager B-Seite	39 Kapselung Bremsabdeckung
9 Läufer	26 Dichtungsring B-Seite	
10 Statorpaket	27 Lüfterflügel	

(...) = wenn vorgesehen

E

1 Tapa externa delantera	11 Armazón	(28) Tapa de protección contra la lluvia
(2) Engrasador delantero	16 Casquete cubre ventilador	29 Escudo posterior portafrenos
3 Cojinete delantero	17 Eje	31 Placa móvil
4 Caja de bornes	18 Anillo de retención delantero	32 Discos de freno
6 Tapa de la caja de bornes	20 Escudo delantero	35 Imán
7 Placa de bornes	22 Fondo interno delantero	37 Piñón dentado
8 Niple paso cables	25 Cojinete trasero	39 Protector del freno
9 Rotor	26 Anillo de retención trasero	
10 Estator	27 Ventilador	

(...) = cuando previsto

I

1 Fondello esterno anteriore	11 Carcassa	(28) Tettuccio parapigioggia
(2) Ingrassatore anteriore	16 Calotta copriventola	29 Scudo posteriore portafreno
3 Cuscinetto anteriore	17 Albero	31 Ancora mobile
4 Scatola morsetti	18 Anello di tenuta anteriore	32 Dischi frenanti
6 Coperchio scatola morsetti	20 Scudo anteriore	35 Magnete
7 Morsettiera	22 Fondello interno anteriore	37 Ingranaggio
8 Niplo passaggio cavi	25 Cuscinetto posteriore	39 Custodia coprifreno
9 Rotore	26 Anello di tenuta posteriore	
10 Statore	27 Ventola	

(...) = quando previsto

GB
F
D
E
I

Motors with external brake
Moteurs à frein externe
Motoren mit äußerer Bremse
Motores con freno externo
Motori con freno esterno

PB
PC
180÷225

6.
6.2

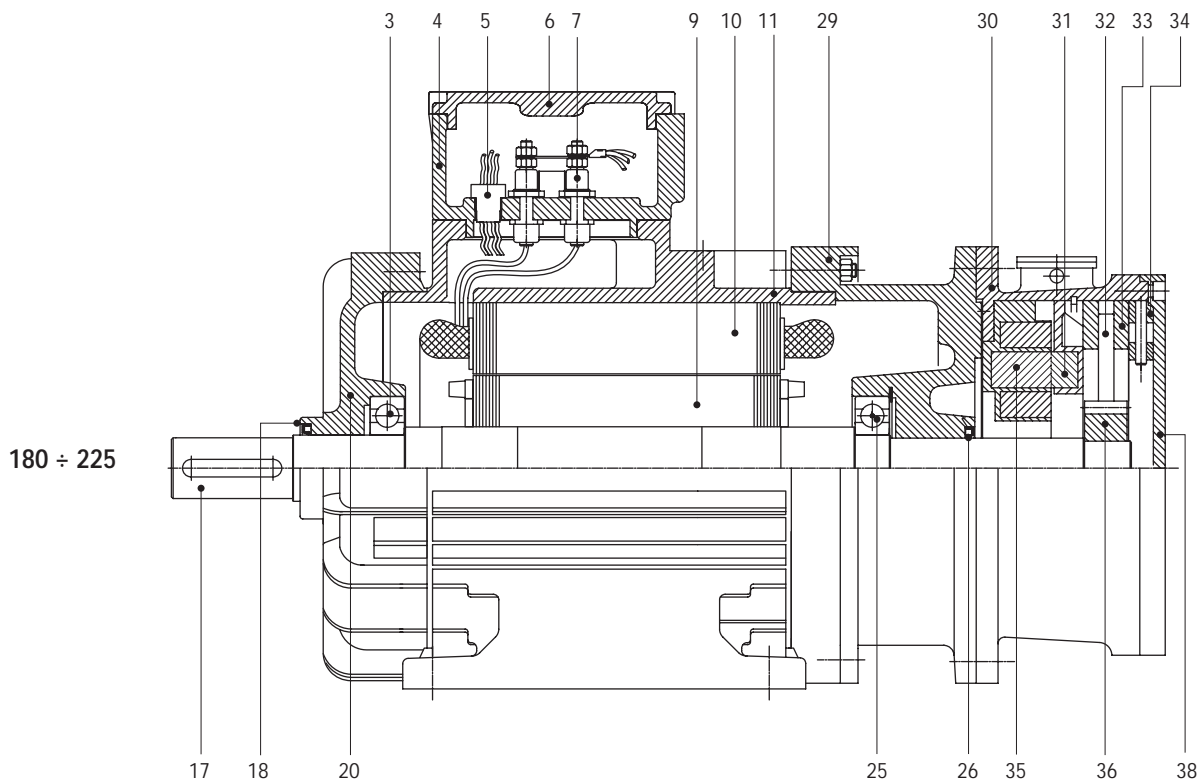

GB

3	Front bearing	11	Frame	31	Mobil armature
4	Terminal box	17	Shaft	32	Braking disks
(5)	Auxiliary connections	18	Sealing ring - front	33	Friction disk
6	Terminal box lid	20	Endshield - front	34	Ring nut
7	Terminal board	25	Rear bearing	35	Magnet
8	Cable nipple	26	Sealing ring - rear	36	Hub
9	Rotor	29	Brake holder back shield	38	Brake cover
10	Stator	30	Brake enclosure		

(...) = when provided

F

3	Roulement avant	11	Carcasse	31	Armature
4	Boîte à bornes	17	Arbre	32	Disques de freinage
(5)	Dispositif pour le passage des auxiliaires	18	Bague avant d'étanchéité	33	Disque de friction
6	Couvercle boîte à bornes	20	Flasque avant	34	Bague
7	Bornes traversante	25	Roulement arrière	35	Aimant
8	Dispositif pour le passage des câbles	26	Bague arrière d'étanchéité	36	Moyeu
9	Rotor	29	Flasque arrière porte-frein	38	Couvercle du frein
10	Stator	30	Carter du frein		

(...) = si c'est prévu

D

3	Kugellager A-Seite	11	Motorgehäuse	31	Anker
4	Klemmkasten	17	Welle	32	Bremsscheiben
(5)	Kabeldurchführung Hilfskreise	18	Dichtungsring A-Seite	33	Reibscheibe
6	Klemmkastendeckel	20	Lagerschild A-Seite	34	Nutmutter
7	Klemmbrett	25	Kugellager B-Seite	35	Magnet
8	Druckfeste Kabeldurchführung	26	Dichtungsring B-Seite	36	Nabe
9	Läufer	29	Lagerschild B-Seite Bremsenhalter	38	Deckel Bremse
10	Statorpaket	30	Kapselung der Bremse		

(...) = wenn vorgesehen

E

3	Cojinete delantero	11	Armazón	31	Placa móvil
4	Caja de bornes	17	Eje	32	Discos de freno
(5)	Niple paso auxiliares	18	Anillo de retención delantero	33	Disco de rozamiento
6	Tapa de la caja de bornes	20	Escudo delantero	34	Anillo
7	Placa de bornes	25	Cojinete trasero	35	Imán
8	Niple paso cables	26	Anillo de retención trasero	36	Cubo
9	Rotor	29	Escudo posterior portafrenos	38	Tapa del freno
10	Estator	30	Envolvente del freno		

(...) = cuando previsto

I

3	Cuscinetto anteriore	11	Carcassa	31	Ancora mobile
4	Scatola morsetti	17	Albero	32	Dischi frenanti
(5)	Nipplo passaggio ausiliari	18	Anello di tenuta anteriore	33	Dischetto d'attrito
6	Coperchio scatola morsetti	20	Scudo anteriore	34	Ghiera
7	Morsettiera	25	Cuscinetto posteriore	35	Magnete
8	Nipplo passaggio cavi	26	Anello di tenuta posteriore	36	Mozzo
9	Rotore	29	Scudo posteriore portafreno	38	Coperchio freno
10	Statore	30	Custodia freno		

(...) = quando previsto

Flameproof-Explosion proof motors

- EEx-d, EEx-de**
- frame size 56 ÷ 315
 - power 0.06 ÷ 132 kW
 - threephase, 1 or 2 speed, singlephase
 - ventilated, unventilated
 - group I, IIA, IIB, IIC
 - category M2, 2G, 2D, 2GD
 - temperature class T3, T4, T5, T6
 - maximum surface temperature [°C] T150, 135, 125, 100, 85, 70
 - with brake

Moteurs antidéflagrants

- EEx-d, EEx-de**
- hauteur d'axe 56 ÷ 315
 - puissance 0.06 ÷ 132 kW
 - triphasés, à 1 ou 2 vitesses, monophasés
 - ventilés, non ventilés
 - groupe I, IIA, IIB, IIC
 - catégorie M2, 2G, 2D, 2GD
 - classes de température T3, T4, T5, T6
 - température superficielle maximum [°C] T150, 135, 125, 100, 85, 70
 - avec frein

Explosiongeschützte Motoren

- EEx-d, EEx-de**
- Baugrößen 56 ÷ 315
 - Leistung 0.06 ÷ 132 kW
 - Drehstrommotoren, 1 oder 2 Geschwindigkeiten, Einphasenmotoren
 - mit Lüftung, ohne Lüftung
 - Gruppe I, IIA, IIB, IIC
 - Kategorie M2, 2G, 2D, 2GD
 - Temperaturklassen T3, T4, T5, T6
 - maximale Oberflächen-temperatur [°C] T150, 135, 125, 100, 85, 70
 - mit Bremse

Motores antideflagrantes

- EEx-d, EEx-de**
- tamaños 56 ÷ 315
 - potencia 0.06 ÷ 132 kW
 - trifásicos, 1 o 2 velocidades, monofásicos
 - autoventilados o no
 - grupo I, IIA, IIB, IIC
 - categoría M2, 2G, 2D, 2GD
 - clase temperatura T3, T4, T5, T6
 - máxima temperatura superficial [°C] T150, 135, 125, 100, 85, 70
 - con freno

Motori antideflagranti

- EEx-d, EEx-de**
- altezza d'asse 56 ÷ 315
 - potenze 0.06 ÷ 132 kW
 - trifase, 1 o 2 velocità, monofase
 - ventilato, non ventilato
 - gruppo I, IIA, IIB, IIC
 - categoria M2, 2G, 2D, 2GD
 - classi di temperatura T3, T4, T5, T6
 - massima temperatura superficiale [°C] T150, 135, 125, 100, 85, 70
 - con freno

Increased safety motors Ex-e

- frame size 63 ÷ 132
- power 0.12 ÷ 7.5 kW
- threephase
- group II
- category 2G
- temperature class T3

Moteurs à sécurité augmentée Ex-e

- hauteur d'axe 63 ÷ 132
- puissance 0.12 ÷ 7.5 kW
- triphasés
- groupe II
- catégorie 2G
- classes de température T3

Motoren für erhöhte Sicherheit Ex-e

- Baugrößen 63 ÷ 132
- Leistung 0.12 ÷ 7.5 kW
- Drehstrommotoren
- Gruppe II
- Kategorie 2G
- Temperaturklassen T3

Motores de seguridad aumentada Ex-e

- tamaños 63 ÷ 132
- potencia 0.12 ÷ 7.5 kW
- trifásicos
- grupo II
- categoría 2G
- clase temperatura T3

Motori a sicurezza aumentata Ex-e

- altezza d'asse 63 ÷ 132
- potenze 0.12 ÷ 7.5 kW
- trifase
- gruppo II
- categoria 2G
- classe di temperatura T3

Non sparking motors Ex-nA

- frame size 63 ÷ 315
- power 0.12 ÷ 132 kW
- threephase, 1 or 2 speed
- group II
- category 3G, 3GD
- temperature class T3

Moteurs anti-étincelles Ex-nA

- hauteur d'axe 63 ÷ 315
- puissance 0.12 ÷ 132 kW
- triphasés, à 1 ou 2 vitesses
- groupe II
- catégorie 3G, 3GD
- classes de température T3

Funkenfreie Motoren Ex-nA

- Baugrößen 63 ÷ 315
- Leistung 0.12 ÷ 132 kW
- Drehstrommotoren, 1 oder 2 Geschwindigkeiten
- Gruppe II
- Kategorie 3G, 3GD
- Temperaturklassen T3

Motores no sparking Ex-nA

- tamaños 63 ÷ 315
- potencia 0.12 ÷ 132 kW
- trifásicos, 1 o 2 velocidades
- grupo II
- categoría 3G, 3GD
- clase temperatura T3

Motori non sparking Ex-nA

- altezza d'asse 63 ÷ 315
- potenze 0.12 ÷ 132 kW
- trifase, 1 o 2 velocità
- gruppo II
- categoria 3G, 3GD
- classe di temperatura T3

Totally enclosed fan cooled IEC motors

- frame size 63 ÷ 315
- power 0.12 ÷ 132 kW
- threephase, 1 or 2 speed
- category 3D
- protection IP55

Moteurs fermés IP 55 CEI/IEC avec ventilation extérieure

- hauteur d'axe 63 ÷ 315
- puissance 0.12 ÷ 132 kW
- triphasés, à 1 ou 2 vitesses
- catégorie 3D
- protection IP55

Geschlossene Motoren mit Fremdbelüftung nach IEC

- Baugrößen 63 ÷ 315
- Leistung 0.12 ÷ 132 kW
- Drehstrommotoren, 1 oder 2 Geschwindigkeiten
- Kategorie 3D
- Schutzart IP55

Motores cerrados con ventilación exterior IP55

- tamaños 63 ÷ 315
- potencia 0.12 ÷ 132 kW
- trifásicos, 1 o 2 velocidades
- categoría 3D
- protección IP55

Motori chiusi con ventilazione esterna CEI/IEC

- altezza d'asse 63 ÷ 315
- potenze 0.12 ÷ 132 kW
- trifase, 1 o 2 velocità
- categoria 3D
- protezione IP55

Centrifugal flameproof electric pumps for printing machines EEx-d - EEx-de

- group IIB, IIC
- output over 300 l/min
- head up to 15 m
- stem length 170 ÷ 550 mm
- special applications
- detachable motor from the pump unit

Electropompes centrifuges antidéflagrantes pour machines d'imprimerie EEx-d - EEx-de

- groupe IIB, IIC
- débit supérieur à 300 l/min
- hauteur de refoulement jusqu'à 15 m
- corps immergé 170 ÷ 550 mm
- applications spéciales
- moteur détachable de l'unité pompe

Explosiongeschützte Zentrifugal-Elektropumpen für Druckmaschinen EEx-d - EEx-de

- Gruppe IIB, IIC
- Leistung bis 300 l/min
- Bis zu 15 m Förderhöhe
- Eintauchtiefe 170 ÷ 550 mm
- Sonderanwendungen
- Motor vom Pumpenkörper abnehmbar

Electrobombas centrifugas antideflagrantes para máquinas de impresión EEx-d - EEx-de

- grupo IIB, IIC
- capacidad: más 300 l/min
- altura: hasta 15 m
- cuerpos sumergidos 170 ÷ 550 mm
- aplicaciones especiales
- motor separable del cuerpo bomba

Elettropompe centrifughe antideflagranti per macchine da stampa EEx-d - EEx-de

- gruppo IIB, IIC
- portate oltre 300 l/min
- prevalenze: fino a 15 m
- corpi immersi 170 ÷ 550 mm
- applicazioni speciali
- motore separabile dal corpo pompa

Centrifugal electric pumps for machine tools

- submersible
- output over 300 l/min
- head up to 30 m
- stem length 90 ÷ 550 mm
- special applications

Electropompes centrifuges pour machines-outils

- immergeables
- débit supérieur à 300 l/min
- hauteur de refoulement jusqu'à 30 m
- corps immergé 90 ÷ 550 mm
- applications spéciales

Elektropumpen für Werkzeugmaschinen

- Eintauchfähig
- Leistung mehr als 300 l/min
- Bis zu 30 m Förderhöhe
- Eintauchtiefe 90 ÷ 550 mm
- Sonderanwendungen

Electrobombas centrifugas para máquinas herramientas

- sumergibles
- capacidad: más 300 l/min
- altura: hasta 30 m
- cuerpos sumergidos 90 ÷ 550 mm
- aplicaciones especiales

Elettropompe centrifughe per macchine utensili

- ad immersione
- portate oltre 300 l/min
- prevalenze fino a 30 m
- corpi immersi 90 ÷ 550 mm
- applicazioni speciali

Every care has been taken to ensure the accuracy of the information contained in this publication.

Due to **Cemp's** policy of continuous development and improvement, the company reserves the right to supply products which may differ slightly from those illustrated and described in this publication.

Descriptions and technical features listed in this brochure may not be considered as binding. Under no circumstances should data in this publication be considered as a contractual obligation.

Dans la préparation de cette documentation nous avons pris le soin d'y intégrer les informations les plus exactes possibles.

Néanmoins, compte tenu de notre politique de développement et d'amélioration continue des produits, la Société **Cemp** se réserve le droit et la faculté d'apporter toute modification sur la documentation et sur les produits, à tout moment et sans préavis.

Les descriptifs et les caractéristiques techniques contenus dans ce catalogue n'engagent pas la Société. Par conséquent, ces données ne constituent en aucun cas un engagement contractuel.

Die Ausführungen und technischen Eigenschaften, die in dieser Broschüre angegeben sind, dürfen nicht als verbindlich angesehen werden.

In keinem Fall können jedoch die in diesem Dokument aufgeführten technischen Daten als rechtlich verbindlich angesehen werden.

Cemp behält sich das Recht vor, ohne Mitteilung, jegliche Abweichungen und Änderungen jederzeit vorzunehmen, sowohl in diesem Dokument als auch bei den Produkten, die hier beschrieben sind.

La presente documentación se ha redactado de manera muy atenta para poder asegurar que las informaciones que contiene son correctas.

No obstante, como consecuencia de la política de continuo desarrollo y mejora de la calidad del producto que **Cemp** pone en práctica, la sociedad se reserva el derecho y la facultad de modificar en lo que fuera necesario, en cualquier momento y sin que para ello medie preaviso alguno, tanto este documento como sus productos.

Por lo tanto, las descripciones y las características técnicas indicadas en el presente documento no son vinculantes, y los datos que contiene no constituyen en ningún caso, vínculo contractual.

Nel redigere questa documentazione è stata posta ogni cura al fine di assicurare la correttezza delle informazioni contenute.

Tuttavia, anche in conseguenza della politica di continuo sviluppo e miglioramento della qualità del prodotto perseguita da **Cemp**, la società si riserva il diritto e la facoltà di apportare modifiche di qualsiasi genere, in qualsiasi momento e senza preavviso, sia a questo documento sia ai propri prodotti.

Le descrizioni e le caratteristiche tecniche della presente pubblicazione non sono quindi impegnative e i dati riportati non costituiscono, in nessun caso, impegno contrattuale.

Cemp SpA

Via Piemonte, 16
I 20030 SENAGO (MI)
Tel. +39 02 99 01 08 04
Fax +39 02 99 89 177
cemp@cemp.eu
www.cemp.eu



Cemp France SA

6 et 8, avenue Victor Hugo
F 27320 NONANCOURT
Tél. +33 (0)2 32 58 03 81
Fax +33 (0)2 32 32 12 98
cemp-france@cemp.eu
www.cemp.eu

Cemp International GmbH

Am Mollnhof 2
D 94036 PASSAU
Tel. +49 (0)851 96 68 68 28
Fax +49 (0)851 96 68 68 29
cemp-deutschland@cemp.eu
www.cemp.eu

Overall sales network at www.cemp.eu
